

# Fast-Joint™

PRECISION JOINERY SYSTEM

Instruction  
Manual  
Part # 3470 ver 2.0



Create joints like these with the

## Fast-Joint™

PRECISION JOINERY SYSTEM

Lolli-pop

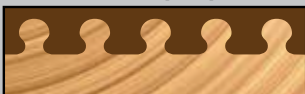

Wave



Through

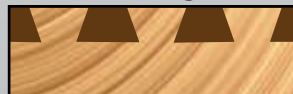

Heart Wave

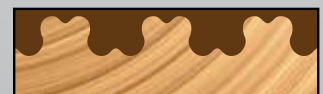

Heart



Half Blind



Arrowhead



Large Key

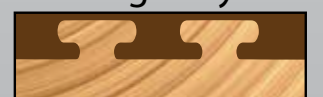

© Copyright Fast Joint Precision Joinery System 8/2011. All images, copy, and graphics are copyrighted by law and may not be copied, or reproduced without our express written consent.

# Fast-Joint™

PRECISION JOINERY SYSTEM

P.O. Box 921487  
Norcross GA, 30010

# Instruction Manual

## *Introduction*

The Fast-joint™ precision joinery system takes a simple approach to making unique woodworking joints. We have done the layout for you and milled one template for the male side and the matching female template for the opposite side of the joint. The hardest part about using the Fast-joint™ system is choosing which style template to use. With our Fast-joint™ precision joinery system you can choose and install templates in a matter of seconds, and once you have made your cut for one side, simply rotate the jig 180° to the other side, it couldn't be any easier. Unlike other template jigs you have seen, our jig will handle 14" stock pieces as well as small hard to handle pieces with an adjustable 3rd hold down toggle. This means the type of projects you can create are virtually endless. Lets get started making some joints.

**But first - let's talk about safety.**

## **Read and follow all safety instructions**

### **Caution:**

Please read, understand and follow all manufacturers instructions, guidelines and owners manuals that come with your power tools. Fast Joint™ and its subsidiaries assume no liability for accidents or injuries caused by improper use of this product.

### **Safety Tips**

Creating joints that look like they have been hand cut will add appeal and distinction to any of your projects. To get the best performance and results out of your Fast-Joint™ system, we recommend the following tips:

1. Always wear safety glasses, hearing protection and dress properly. No loose clothing, hair, draw strings or jewelry that might get caught in moving parts.
2. Keep work area clean. Messy work areas invite injuries.
3. Make deeper or larger cuts in multiple passes and NEVER use dull cutters. Forcing a deep cut in one pass or using a dull cutter can result in injury. Inspect cutters for damage or chips in carbide.
4. Make sure router bit is properly installed in router and do not exceed the recommended rpm
5. Keep all safety guards in place.
6. Always unplug your tools before changing cutters or making adjustments to the bit or the router.
7. Secure you work. Always use at least two clamps to hold your stock to the jig. Make sure the clamps do not interfere with the cutters on the under side of the jig.
8. Make sure the jig is clean with no build up or debris for smooth operation.
9. This system is designed for use on router tables only, do not use with a free hand router set-up.
10. Follow all manufacturer safety guidelines provided with you router.
11. Support longer stock properly so that it does not shift or change the position of the jig.

## ***Fast-joint™*** precision joinery system **Package Contents**

- |  |                                      |
|--|--------------------------------------|
| 1 Ea. Fast-joint™ aluminum jig platform                            | 1 Ea. 3/16" up cut spiral router bit |
| 3 Ea. toggle clamps  | 1 Ea. 14° dovetail router bit        |
| 3 Ea. bushings   | 1 Ea. brass centering pin            |
| 1 Ea. bushing spring washer  | 2 Ea. spring clamps                  |
| 1 Ea. half blind dovetail set                                      | 1 Ea. 3/8" x 3/8" brass set-up bar   |
| 1 Ea. heart template set   | 1 Ea. right angle fence              |
| 1 Ea. key template set   | 2 Ea. abrasive strips                |
| 1 Ea. through dovetail tail template<br>(works with 1/2 blind set) | 1 Ea. MDF backer board               |
|  | 1 Ea. set up block                   |
|  | All necessary hardware for assembly  |



# Fast-joint™

precision joinery system

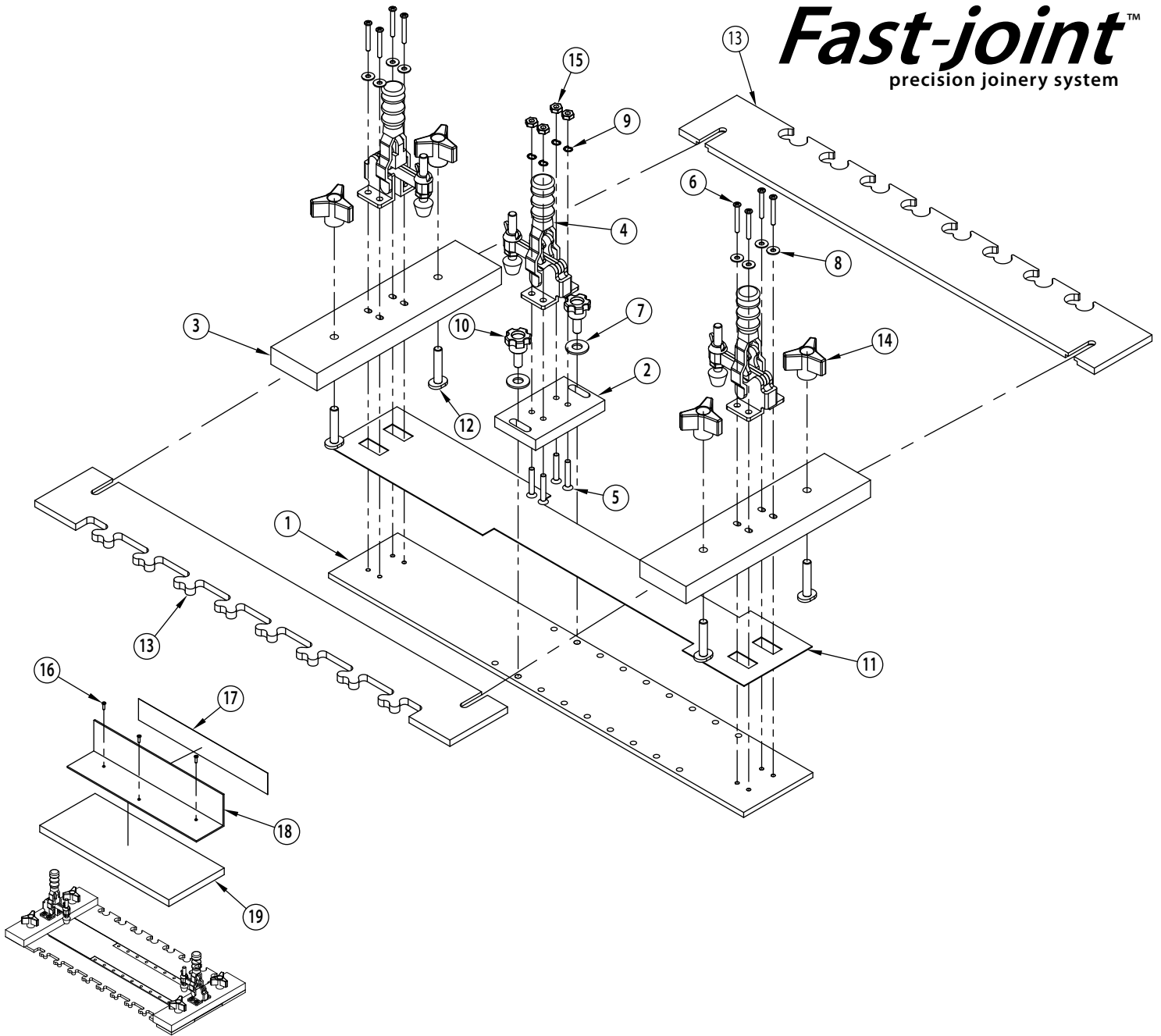

Part #	Part Description	Quantity
1	Base Plate	1
2	Position Set-up Block	1
3	Template Alignment Blocks	2
4	Toggle Clamps	3
5	Machine Head Screws	4
6	1" Panhead Screws	8
7	Washers	2
8	Mini - Washers	8
9	Lock Washers	4
10	Mini-stud Knobs	2
11	Stamped Non-slip Sandpaper	1

Part #	Part Description	Quantity
12	T-bolts	4
13	Heart Templates	1 set
14	Star Hole Through Knobs	4
15	Nuts	4
16	Panhead wood screws	3
17	Non-slip Sandpaper Strip	1
18	Aluminum Angle Fence	1
19	MDF sub-plate	1
	Half-Blind Dovetail Template	1 set
	Key Template	1 set
	Through Dovetail Template	1 set

## Fast-joint™ Assembly

### Step 1 - Installing Sandpaper:

Peel the backing off the self adhesive stamped sandpaper strip (part #11). Place the strip on to one side of the aluminum base plate (part #1). Align the sandpaper strip so that the cutouts do not interfere with any of the pre-drilled holes on the aluminum base plate (See Fig. 1).



### Step 2 - Install Template Alignment Blocks:

First, assemble the rubber feet on to the three toggle clamps. Using four 1" panhead screws (part #6), four washers (part #8), one hold down toggle (part #4) and one template alignment block (part #3), install the panhead screws with washers through the toggle mounting holes and the template alignment block holes into the base plate (part #1). Make sure the rubber foot of the toggle faces to the inside of the base plate. Do not tighten the screws completely, leave some play for adjustment. Once complete repeat this step on the opposite side (See Fig. 2). We have left the eight screws loose to allow us to square up the jig later.

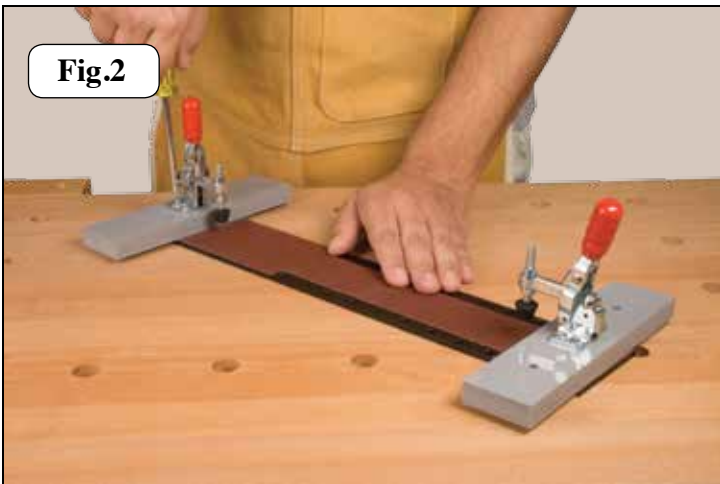

### Shop Notes:

*The non-slip sandpaper is installed on our jig to minimize movement of the stock. Over time the strip will have to be replaced. We have installed the template alignment blocks on top of the non-slip sandpaper for two reasons: First, once we have squared the jig, it helps keep the template alignment blocks from moving. Second, it aligns the stock flush with the top of the template we are using.*

### Step 3 - Installing Star Knobs & T-Bolts:

Install the four T-bolts (part #12) through the holes on the template alignment blocks and thread the four star knobs (part #14) on to each respective T-bolt. Do not completely tighten the star knobs (See Fig. 3).



### Step 4 - Squaring of Fast Joint Jig:

In order for the Fast-Joint system to work properly, it is imperative that the left and right template alignment blocks are parallel to one another and square to the base plate. It does not matter what set of templates you use for this process. In our example we will be using the Heart template. Place a square against one edge of the base plate and the other edge of the square against the left template alignment block, making sure the left template alignment block of the jig is square to the base plate (See Fig. 4). Tighten the four screws of the toggle clamp.

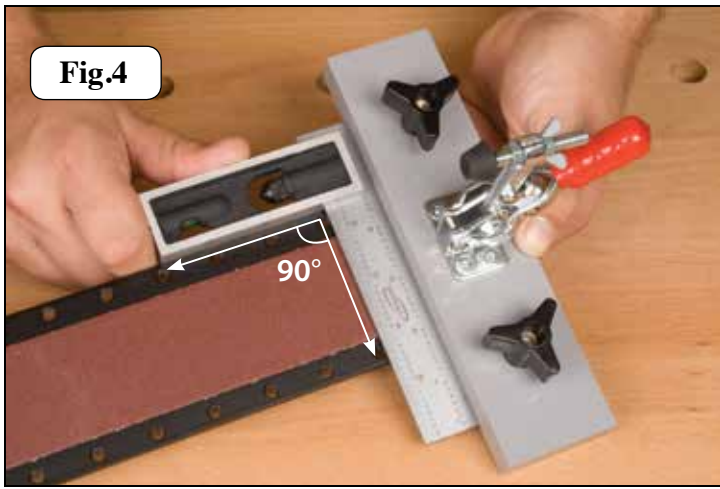
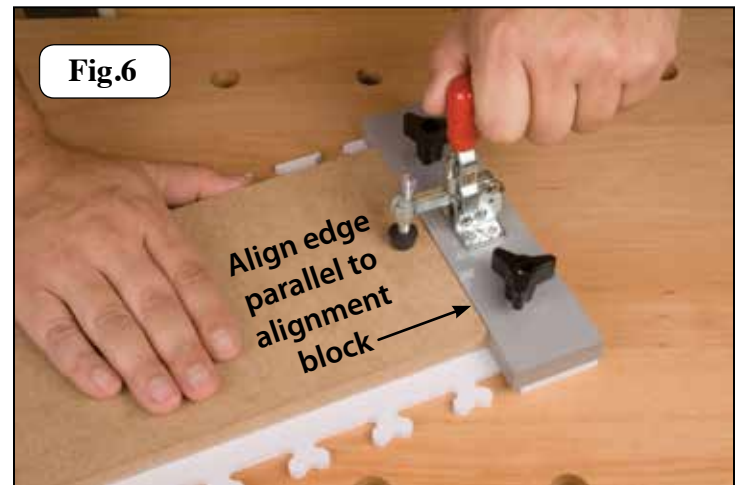

**Fig.4**

Next, we will be using the MDF sub-plate (part #19) to align - parallel and square the right hand template alignment block on the Fast-joint™ jig. Place the sub-plate on top of the base plate between the template alignment blocks. Align the left edge of the MDF sub-plate parallel to the edge of the template alignment block. Adjust the left toggle foot for the thickness of the MDF sub-plate. Clamp the MDF sub-plate down to the base plate using the left toggle clamp (See Fig. 6).

Install the template marked female on to the T-bolts so that the T-bolt head fits into the recess on the bottom of the template. Make sure the female template is pushed flat against the base plate. Tighten the knob on the left hand side only. We do not completely tighten the knob on the right hand side to allow for adjustment to the right template alignment block later.

Install the template marked male on to the T-bolts so that the T-bolt head fits into the recess on the bottom of the template. Make sure the male template is pushed flat against the base plate. Tighten the knob on the left hand side only (See Fig. 5). We do not completely tighten the knob on the right hand side to allow for adjustment to the right template alignment block later.

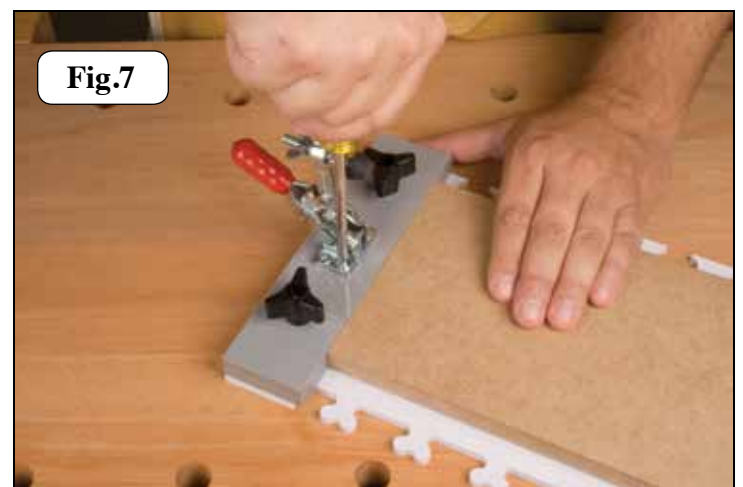

**Fig.6**

With the MDF sub plate secured in place, Align the right inside edge of the template alignment block parallel to the edge of the MDF sub-plate and tighten the four screws on the toggle clamp, securing it to the base plate (See Fig. 7). Once template alignment block is fastened, tighten the other two star knobs, securing the right side of the Heart templates.

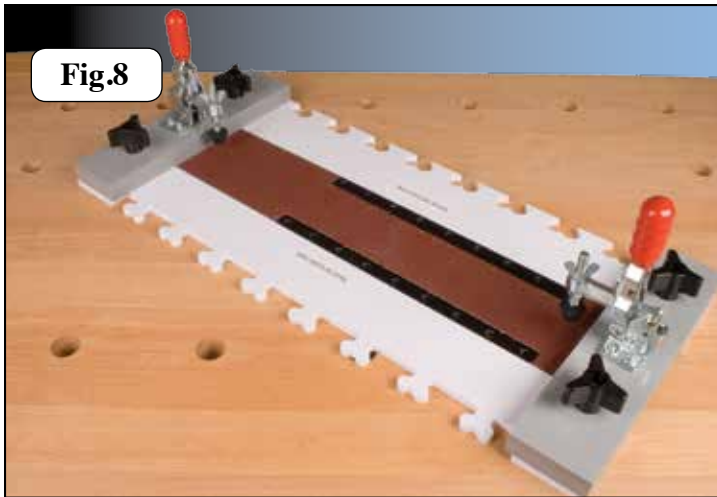

**Fig.5**



**Fig.7**

With both the left and right template alignment blocks fastened to the base plate, unlock the left toggle and remove the MDF base plate. Your Fast-joint™ jig should look like the photo below (See Fig. 8).



Temporarily secure the third toggle (mounted) into any of the threaded holes in base plate, using the two mini stud knobs (part #10) and washers (part #7) (See Fig. 11).

*Shop Notes:*

Once you have fastened the left and right template alignment blocks to the base plate, the MDF sub-plate should slide front to back without binding (See Fig. 9). If it does not slide, this indicates that the template alignment blocks are not parallel. If so, repeat adjustment of the templates alignment blocks until the MDF slides smoothly.

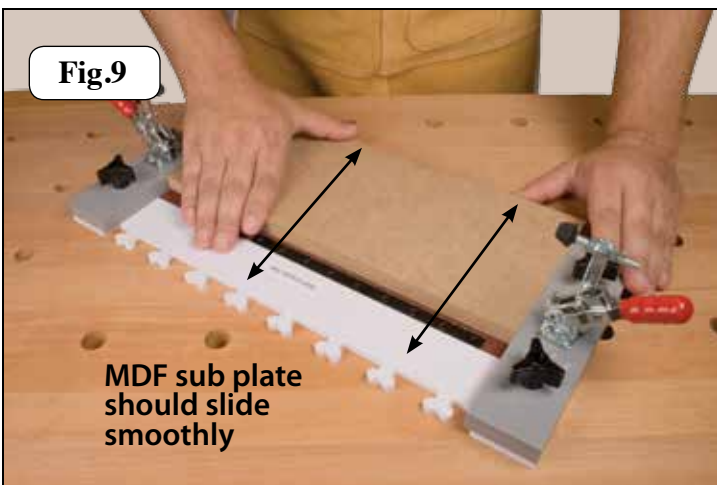
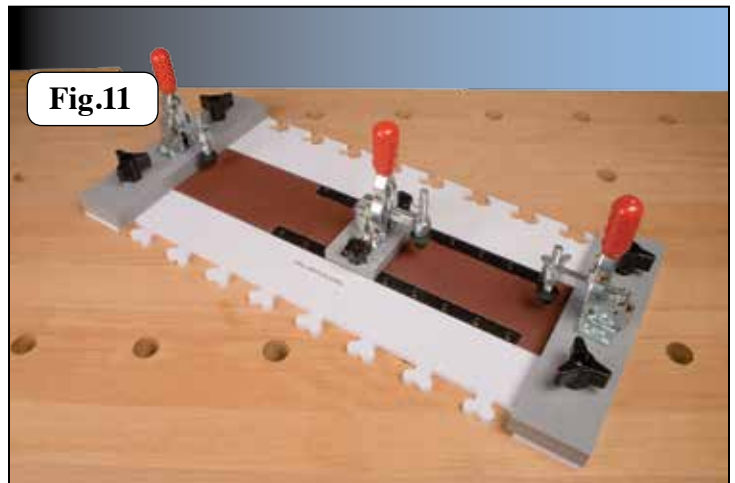

*Shop Notes:*  
The third toggle is used for any stock that is 2" to 12" wide to prevent lifting and provide even, solid holding pressure.

Using the four machine head screws (part #5) fasten the toggle to the position set-up block (part #2) (See Fig. 10).

**Step 5 - Assemble Right Angle Fence**

The right angle fence used with female template side of the jig and is attached to the MDF sub-plate. Peel the backing off the self adhesive sandpaper strip (part #17). Place the strip on the outside surface of the aluminum angle fence (part #18) that does not have pre-drilled holes (See Fig. 12)



**Fig.12**

It is important that the edge of the MDF sub-plate is flush with the non-slip sandpaper to prevent the stock from rocking in the jig. A simple way to do this is to place the right angle fence on a flat surface with the sandpaper side facing down. Stand the MDF sub-plate up against the right angle fence, and align the two outer edges to the right angle fence. Temporarily clamp the MDF sub-plate and the right angle fence together with c-clamps (See **Fig. 13**).



**Fig.13**

With the components clamped together and flush, use the three pan head screws (part #16) to fasten the right angle fence to the MDF sub-plate (See **Fig. 14**).

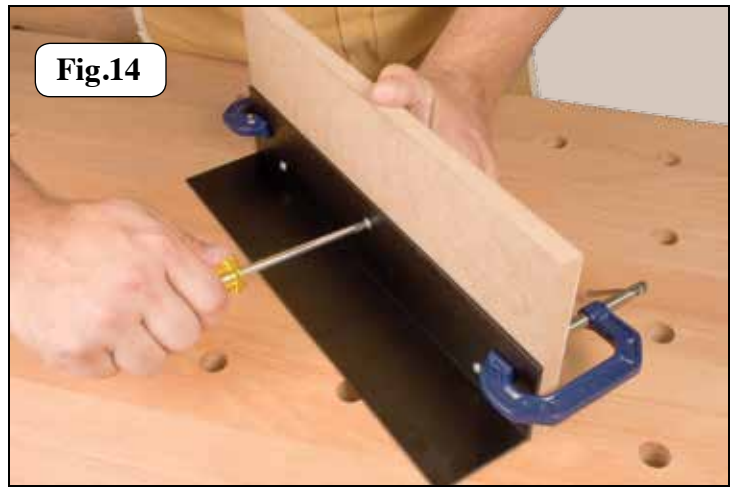

**Fig.14**

Once secured, remove the two C-clamps and your final assembly of the right angle fence and MDF sub-plate should be flush and look like the photo shown below in **Fig. 15**.

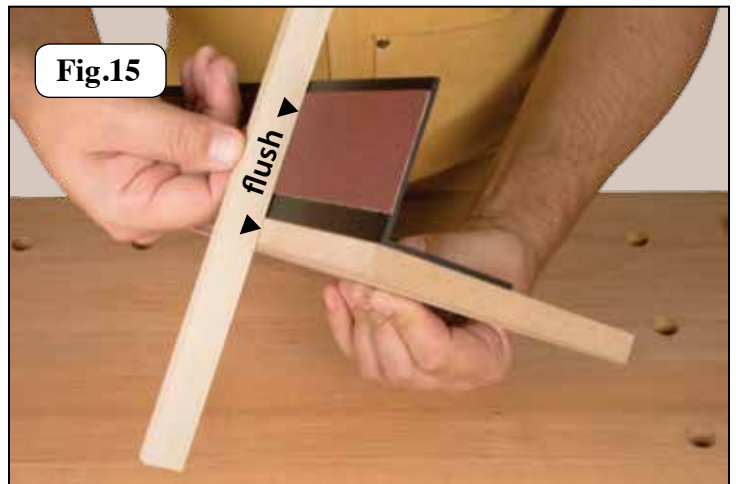

**Fig.15**

Your completed Fast-joint™ jig system and right angle fence should look like the photograph shown below in **Fig. 16**).

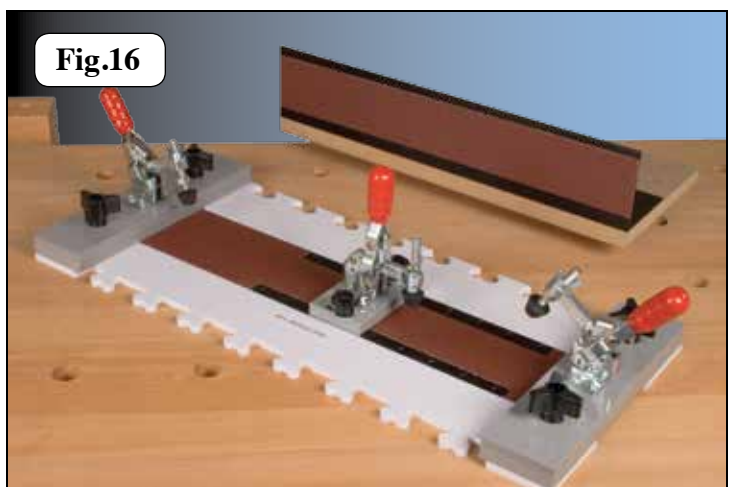

**Fig.16**

## Router Set-up

Included with your Fast-joint™ system are three different size brass bushings that will fit into most router plates with a 1-1/4" opening with a rabbeted off-set of 1-3/8". One bushing is marked "standard" (A), which is used with the 3/16" upcut spiral bit on most of the templates. The second bushing is marked "tight" (B) which is used with the 3/16" upcut spiral when you would like to tighten the joint. The third is marked 7/16" (C), which is to only be used with the 14° dovetail router bit. A locking nut (D), spring washer (E) and the brass centering pin (F) are also included with your system. (See Fig. 17).

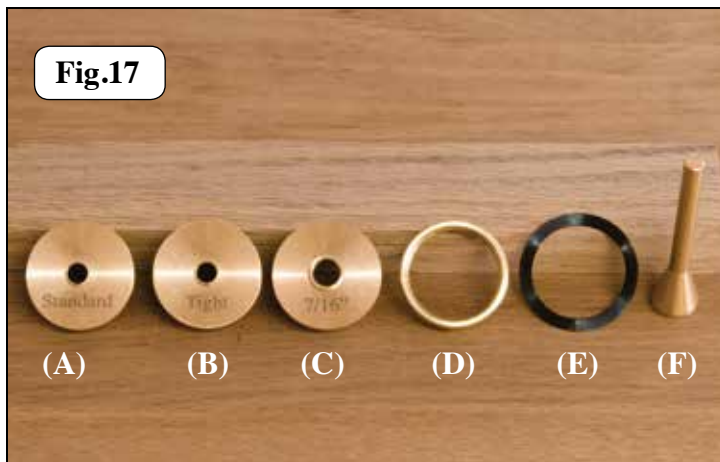

Fig.17

### Shop Notes:

*In order for the system to work, it is imperative that your router bits are centered in the brass bushings. If you do not have your router centered, it will throw the joint off and possibly allow the cutters to damage the brass bushings.*

### Centering Your Router On To The Plate:

Insert the standard bushing into your router plate, next place the spring washer and locking nut on the underside and tighten locking nut securely. With your router un-plugged, insert the 3/16" upcut spiral router bit and secure router collet. Raise the router with bit through the hole in the brass bushing. Using your hand, reach under the table and spin the router bit slowly, checking the router bit for alignment (See Fig. 18). The router bit should have equal spacing all the way around the inside of the brass bushing. If the router bit is touching the side of the brass bushing, or is off-set to one side, you will need to re-align the router to the center of the router plate and bushing.



Fig.18

### Caution

*Always make sure router is un-plugged before checking location to the router bit. Do not try to spin the router bit by the cutting edge, as this may result in injury. Always spin the router bit by reaching under the table and spin the bit from the router collet.*

To align your router with the center of your brass bushing, your Fast-joint™ system comes with a brass centering pin. With the router Un-plugged and the standard bushing installed on the router plate, loosen the screws that hold your router plate to your router just enough to allow for adjustment. Insert brass centering pin through the bushing into the 1/4" router collet of your router and tighten router collet. Lower router until the cone on the brass centering pin contacts the standard bushing evenly (See Fig. 19). Tighten the screws that hold your router plate to your router. Your router should now be centered to the router plate.



Fig.19



### Caution

*DO NOT* turn router on with the centering pin in the router collet. Doing so may result in injury.

### Shop Notes:

*You may need to re-drill and re-mount your router to the router plate if the router and the router bit are too far off center. Use your centering pin to align the router plate to the router for re-drilling.*

This is what your Fast-joint™ system should look like when using the 3/16" router bit with Heart templates. (See Fig. 20).

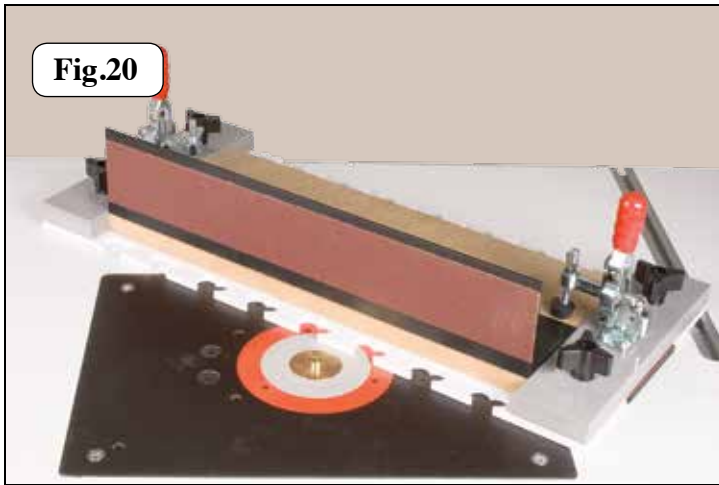

### Stock Preparation

When cutting your joints with the Fast-joint™ system, make sure your stock is flat, and that the edge you will be milling is straight. The unique feature about this system is, you can cut any length or any width stock. Your Fast-joint™ system will work with the same thickness stock on both sides of the joint, or use one thickness piece of stock on one side of the joint and use a different thickness piece of stock on the other side of the joint. You can even cut angle joints with the Fast-joint™ system. Now that we have assembled and squared the Fast-joint™ system, we are ready to cut some joints. Note: it's a good idea to make test cuts on sample stock before making your actual cut.

### Shop Notes:

*Each of the templates that come with the Fast Joint system are spaced differently. When working on a project, check your stock width to see if the pattern will align evenly on both sides of the stock when placed up against the template alignment block. If the stock is not equally spaced on both edges, use a spacer block before starting your cuts.*

*(refer to "Centering Your Material", page #29)*

### Four Sided Box

The type of joint we will be making is referred to as a half blind joint. Which means, you will only see the joints on the sides of the box. The front and back of your box must be made from a minimum of 3/4" stock. The sides of your box can be made from 1/4" to 3/4". In the following example we will be building a 10" square - four sided box using the heart templates. The front and back of the box will be made from 3/4" x 10" long stock using the female template and the sides of the box will be made from 3/8" x 9-3/4" stock using the male template. Use the same species of stock, or for contrast, use a darker type of wood on the sides of the box and a lighter type of wood on the front and back of the box.

### Shop Notes:

*When cutting the sides of our box we subtract 1/4" from the planned finished size (10") we are making.*

### Set-up the router bit height:

Now we have to set the height of the bit. The bit height is always set from the thickness of the male stock (sides of the box). We are using 3/8" thick stock on the sides of our project, which means the bit needs to be set at a cutting height of 3/8". You can use a ruler to do this, or an easier way to do this is to use the thickness of your stock to set the height of the bit. Using your Fast-joint™ system with the Heart templates installed along with your standard bushing, 3/16" router bit, and router installed into your router table, slide your Heart template against the brass bushing. Place your stock on top of the Fast-joint™ system aligning one edge with the edge of the template. Raise the bit until it is flush with the top of your stock and lock the router bit height in place (See Fig. 21).

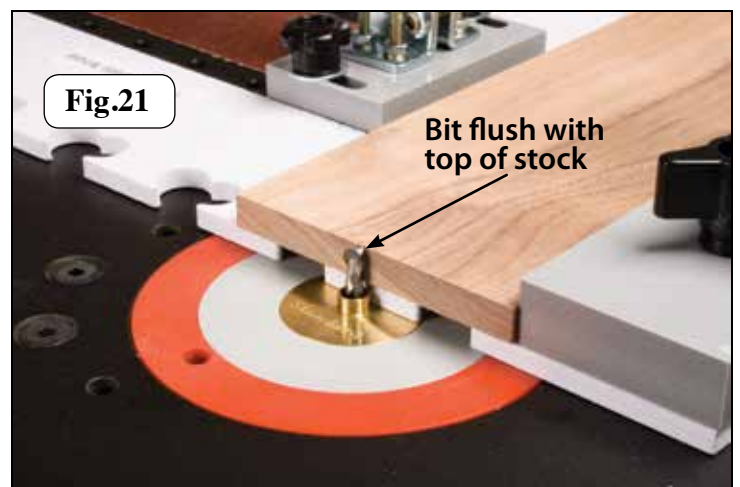

## Set-up For The Sides of the Box:

Part of what makes the Fast-joint so easy to use is the machined set-up block. This block allows you to easily position your stock, to the off-set distance between the router bit cutting surface and the outer edge of the brass bushing. We will be making the cuts on the side of our box first using the male Heart template on the jig. For this cut you can place the stock flat on either the left side or the right side of your jig. Place a reference mark on side edge of the stock (X). This edge must always be placed up against the template alignment block for the joint to align properly. Adjust the rubber feet on the toggles for the thickness of the stock you are cutting. Your toggle clamp should produce a slight snap when engaged. If the toggle is too tight it may cause the jig to flex. If you are cutting smaller stock, add the third toggle to the jig and adjust the third toggle for the thickness and width of stock if needed. With your stock on the jig and your reference mark facing the template alignment block, place your gray set-up block with the wide side facing down on your router table. Slide the block up against the edge of the male Heart template. While holding the set-up block against the edge of the Heart template, slide your stock up against your template alignment block. Next, slide your stock forward until it contacts the set-up block and secure the stock in place with toggle clamp. (See Fig. 22).

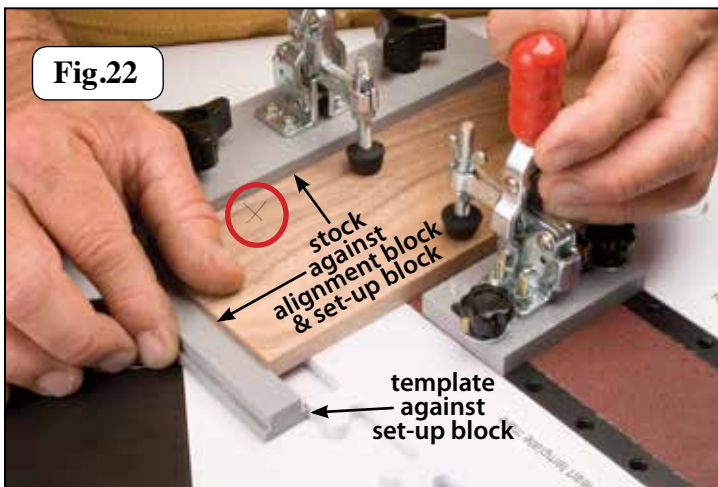

### Shop Notes:

*Always use a minimum of two clamps when securing your stock to the jig. This prevents the material from moving. Not doing so may result in a sloppy joint or even injury.*

## Making The Cut:

The first time you use each style of template, it is perfectly normal to cut into the template alignment blocks. The template alignment blocks are made from a durable polyethylene plastic, and should last for many projects. At the point that they no longer provide support, you can reverse them and use the outer edges or replace them with new ones. We start our cut approximately 1/4" in from the inside edge of the template alignment block. Make sure the router bit is not contacting the surface of the stock or any part of the Fast-joint jig before turning on your router. Turn the router on. Firmly grasp the jig at both ends and slide the jig forward until the template contacts the bushing (See Fig. 23).



### Caution

*When the first cut is made into the plastic template alignment blocks, the router bit may have a tendency to grab the jig and cut excessively.*

Once contact is made, slowly guide the profile of the template against the bushing and router bit so that your material is cut in the shape of the template, working from the outer edge of the jig to the inside edge of your stock. (See Fig. 24)



After the first cut is made, you should make multiple passes to make sure all the material has been removed, working from the outer edge of the jig to the inside edge of your stock. Your finished cut should resemble the photograph shown below in **Fig. 25**.



Your completed side pieces should resemble the photograph shown in **fig. 27**.



### *Shop Notes:*

*Always make sure that no chips or saw dust are caught between the template and the bushing. If there is any debris, it may result in poorly fitting joints.*

Now that one end of the box is cut, you will now flip the stock, keeping your reference mark (X) against the template alignment block, and following the same instructions shown in **fig. 22**. for set-up. Once the stock is properly set-up and secure in the jig, make the cut (See **Fig. 26**). After making this cut, repeat this entire process on the other side of your box.

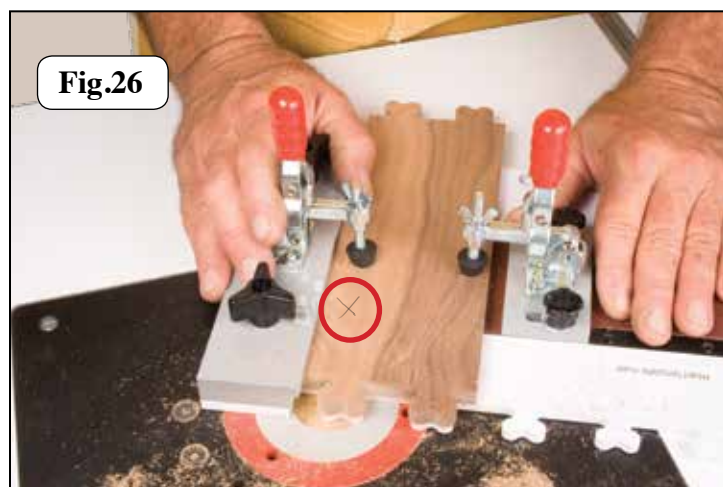

### *Shop Notes:*

*Always remember to keep the reference mark (X) you made against the template alignment block. Failing to do so may result in un-even joints.*

### **Set-up For The Front & The Back of Box**

Now that the sides of our box are complete we need to cut the front and back. The height of the router bit does not change for this cut. We will be making the cuts on the front and back of our box using the female Heart template on the jig with the right angle fence. If you were using the third toggle, you will now remove it from the jig. Place the right angle fence on to the jig between the template alignment blocks, with the non-slip abrasive strip facing the female side of the jig. Adjust the rubber feet on the toggles for the thickness of the MDF sub-plate. Your toggle clamp should produce a slight snap when engaged. If the toggle is too tight it may cause the jig to flex. Place a reference mark on the side edge of the stock (X). This edge must always be placed up against the template alignment block for the joint to align properly. Place the front of your box vertically, on the jig, in front of the right angle fence, with the reference side against the template alignment block. With your stock on the jig and your reference mark facing the template alignment block, place your gray set-up block with the wide side facing down on your router table. Slide the block up against the edge of the female Heart template. While holding the set-up block against the edge of the Heart template, slide the right angle fence and stock up against your set-up block until flush. Secure the MDF sub-plate with toggle clamps (See **Fig. 28**).

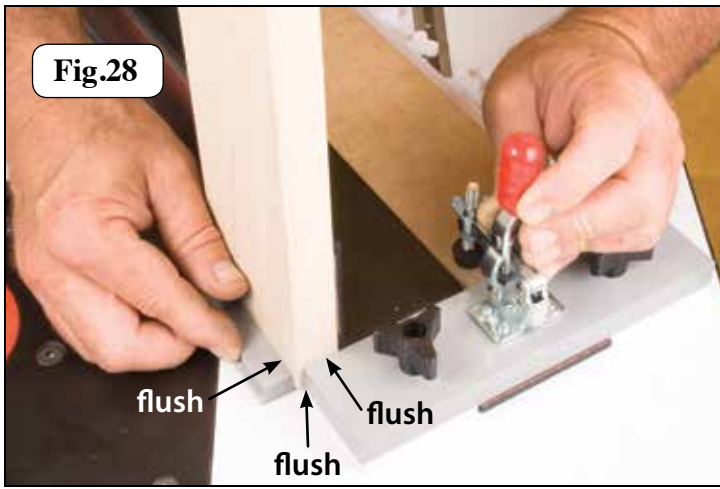

Now that the right angle fence is secure, slide the reference side of the stock against the template alignment block. Clamp the stock to the right angle fence using the two spring clamps that came with the Fast-joint™ system (See Fig. 29).

*Shop Notes:*

*If you are cutting long stock, it is recommended to clamp your stock to the right angle fence using C-clamps or F-clamps.*



**Caution**

*When clamping your stock to the right angle fence, always make sure that the clamps do not interfere with the cutters. Doing so may result in damaging your cutters or even injury.*

**Making The Cut:**

The first time you use each style of template, it is perfectly normal to cut into the template alignment blocks. The template alignment blocks are made from a durable polyethylene plastic, and should last for many projects. At the point that they no longer provide support, you can reverse them and use the outer edges or replace them with new ones. We start our cut approximately 1/4" in from the inside edge of the template alignment block. Make sure the router bit is not contacting the surface of the stock or any part of the Fast-joint™ jig before turning on your router. Turn the router on. Firmly grasp the jig at both ends and slide the jig forward until the template contacts the bushing (See Fig. 30).



**Caution**

*When the first cut is made into the plastic template alignment blocks, the router bit may have a tendency to grab the jig and cut excessively.*

Once contact is made, slowly guide the profile of the template against the bushing and router bit so that your material is cut in the shape of the template, working from the outer edge of the jig to the inside edge of your stock. (See Fig. 31)



After the first cut is made, you should make multiple passes to make sure all the material has been removed, working from the outer edge of the jig to the inside edge of your stock. Your finished cut should resemble the photograph shown below in **Fig. 32**.

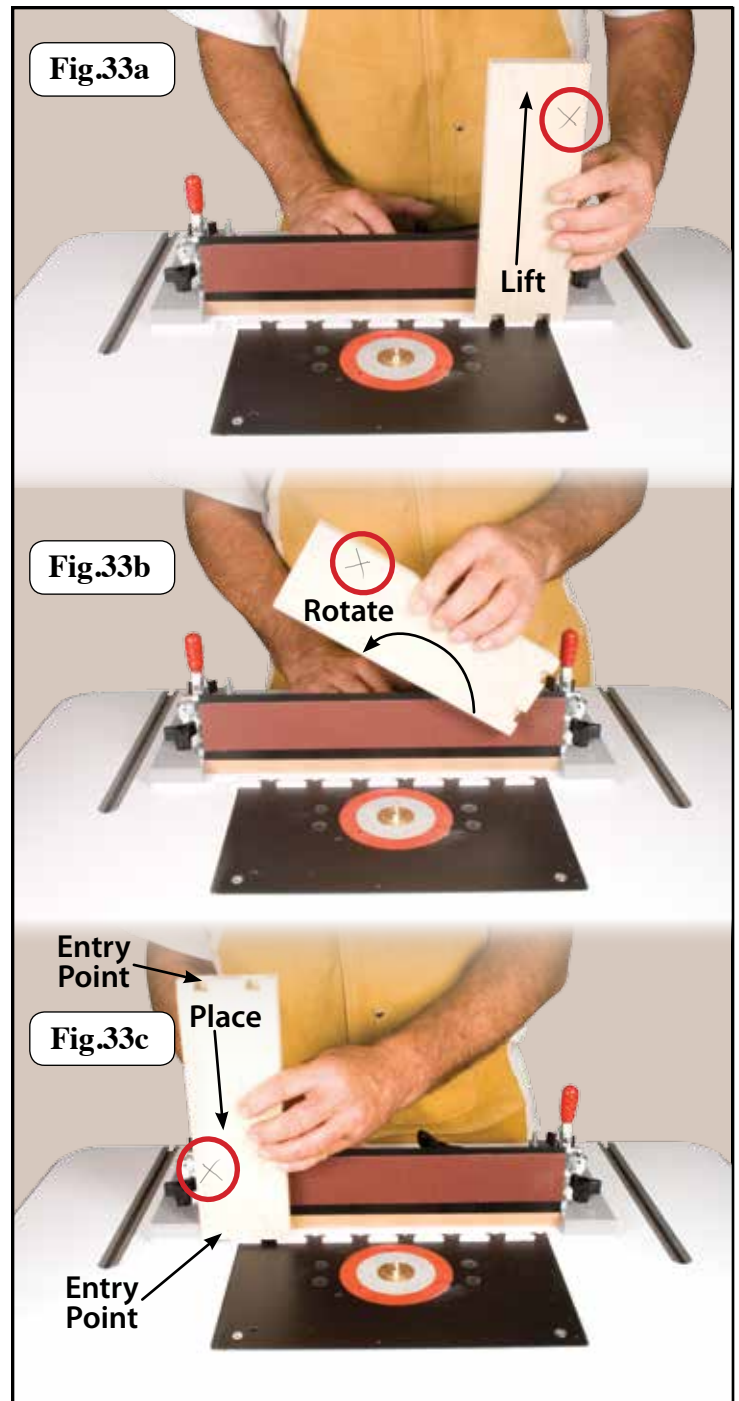
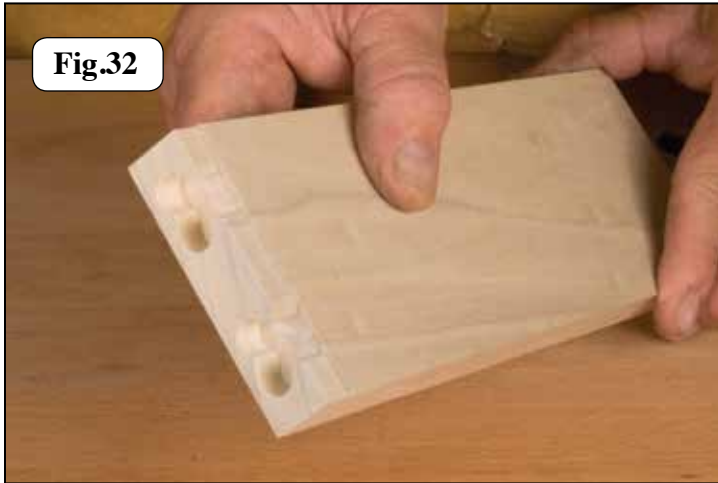

*Shop Notes:*

*Always make sure that no chips or saw dust are caught between the template and the bushing. If there is any debris, it may result in poorly fitting joints.*

*Shop Notes:*

*Always remember to keep the reference mark you made against the template alignment block. Failing to do so may result in un-even joints.*

Now that one end of the box is cut, you will now cut the opposite end of the stock using the same reference mark. In order to do this, you will place the opposite end of the stock vertically on the other side of the jig, in front of the right angle fence, with the reference (X) side against the opposite template alignment block (See **Fig. 33a, 33b, and 33c**). The reason why we move to the other side of the jig, is to have the same entry point on the opposite side of the stock we are cutting, so that all four sides of the box will fit together properly (See **33c**).

Once in place following the same instructions shown in **fig. 28**. for set-up. Once the stock is properly set-up and secure in the jig, make the cut (See **Fig. 34**). After making this cut, repeat this entire process on the back side of your box.

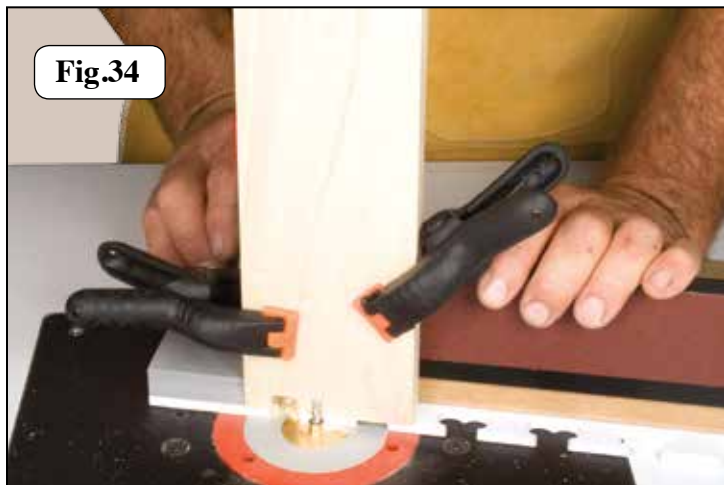

**Fig.34**

### Assemble the box:

Assemble all four sides of the box. Your completed box should resemble the photograph shown below in **Fig. 36**. The joints should have a snug - sliding fit. If you have to force the joint together with a mallet, it may result in splitting your stock, as well as forcing the glue out of the joint. To loose of a fit may produce wobbling and a weak joint. If satisfied with the fit of your joints, glue, clamp and finish your project. If your joint needs adjusting see page #32 "Fast-Joint Tips".



**Fig.36**

Your completed front and back pieces should resemble the photograph shown below in **fig. 35**.



**Fig.35**

Follow these same basic instructions for cutting the Hearts template, Key template, Heart Wave template, Large Key template, Lock template, Wave template, Lolli-pop template, Arrowhead template and Teddy bear template. The Half-blind dovetails and Through dovetails require different instructions which will be outlined later in this manual.

## Recessed Style Joint

Recessed style joints are an easy way add depth to the joint. What some woodworkers like to do with this joint is, after assembly slightly soften the female side of the joint with sandpaper to give it a country feel. This style of joint we will be making is exactly the same as the four sided box we just made with one exception. When we cut the front and back pieces of our box, we raise the height of the router bit. We will be using the Heart templates in this example, the front and back will be made from 3/4" stock, the sides will be made from 3/8" stock and will be recessed into the front and back by 1/4".

### Set-up For The Sides of The Box:

Follow the instructions outlined on page #9 starting with "Set Up Router Bit Height" all the way through to and including pages #10 & #11 "Making The Cut". Your two side pieces should resemble shown below in Fig. 37.



### Set-up For The Front & The Back of Box

Now that the sides of our box are complete we need to cut the front and back. We need to raise the height of the router bit 1/4". Your final height of your router bit should now be approximately 5/8". We will be making the cuts on the front and back of our box using the female Heart template on the jig with the right angle fence. If you we're using the third toggle, you will now remove it from the jig. Place the right angle fence on to the jig between the template alignment blocks, with the non-slip abrasive strip facing the female side of the jig. Adjust the rubber feet on the toggles for the thickness of the MDF sub-plate. Your toggle clamp should produce a slight snap when engaged. If the toggle is too tight it may cause the jig to flex. Place a reference mark (X) on the side edge of the stock. This edge must always be placed up against the template alignment block for the joint to align properly. Place the front of your box vertically, on the jig,

in front of the right angle fence, with the reference side against the template alignment block. With your stock on the jig and your reference mark facing the template alignment block, place your gray set-up block with the wide side facing down on your router table. Slide the block up against the edge of the Heart template. While holding the set-up block against the edge of the Heart template, slide the right angle fence and stock up against your set-up block until flush. Secure the MDF sub-plate with toggle clamps (See Fig. 38).

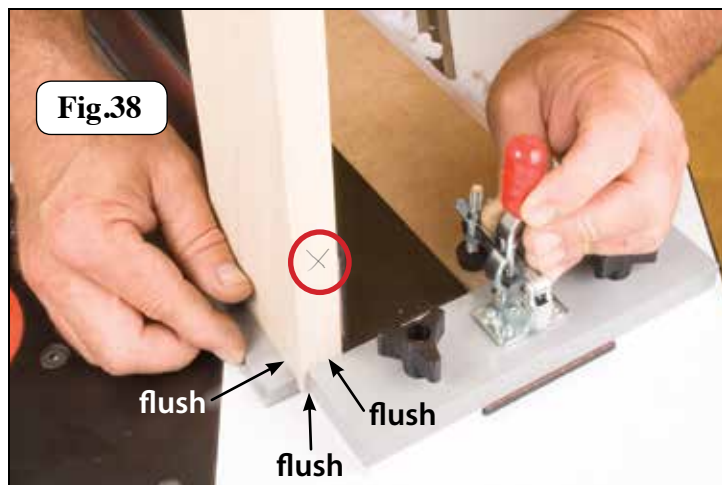

Now that the right angle fence is secure, slide the reference side of the stock against the template alignment block. Clamp the stock to the right angle fence using the two spring clamps that came with the Fast-joint system (See Fig. 39).

### Shop Notes:

*If you are cutting long stock, it is recommended to clamp your stock to the right angle fence using C-clamps or F-clamps.*

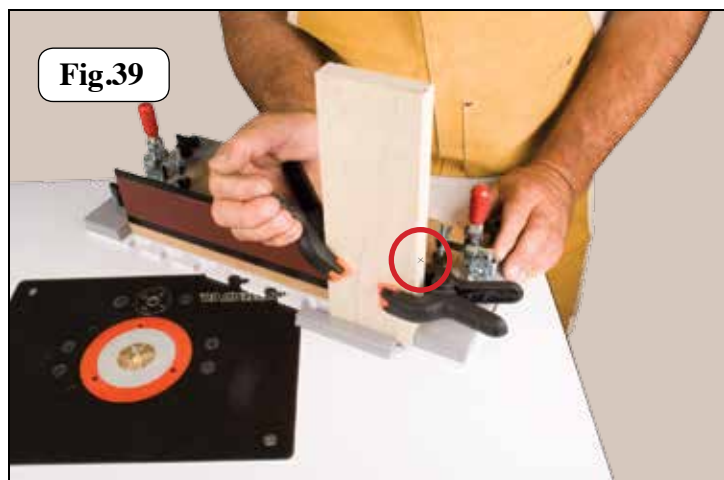

## Making The Cut:

With your stock secured in the jig, follow all of the instructions outlined on page #12 "Making The Cut" all the way through to page #13. Your completed front and back pieces should resemble the photograph shown below in **Fig. 40**.



## Assemble the box:

Assemble all four sides of the box. Your completed box should resemble the photograph shown below in **Fig. 41**. The joints should have a snug - sliding fit. If you have to force the joint together with a mallet, it may result in splitting your stock, as well as forcing the glue out of the joint. To loose of a fit may produce wobbling and a weak joint. If satisfied with the fit of your joints, glue, clamp and finish your project. If your joint needs adjusting see page #32 "Fast-Joint Tips".

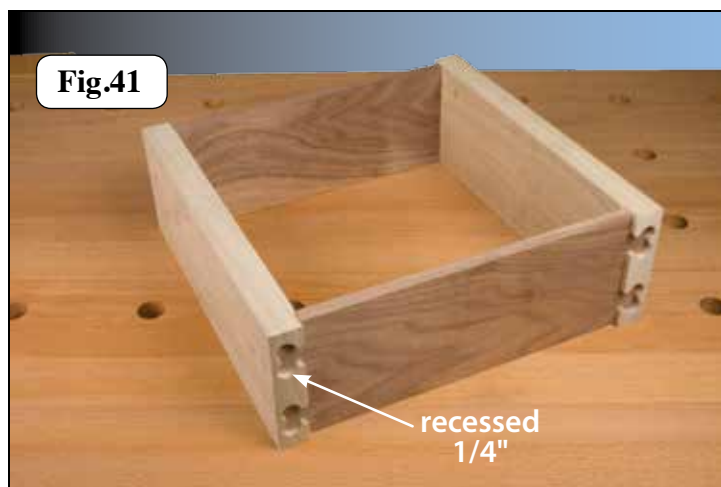

Follow these same basic instructions for cutting the Hearts template, Key template, Heart Wave template, Large Key template, Lock template, Wave template, Lolly-pop template, Arrowhead template and Teddy bear template.

## Three Dimensional Joint

Three Dimensional style joints will extend the joint through the front and back of the box. This will give your joint a pronounced look. This style of joint we will be making is exactly the same as the four sided box we just made with one exception. The front and back of the box will be made from 1/2" thick stock. We will be using the Heart templates in this example, the front and back will be made from 1/2" stock, the sides will be made from 3/8" stock and will be protruding out of the front and back by 1/4".

## Set-up For The Sides of The Box:

Follow the instructions outlined on page #9 starting with "Set Up Router Bit Height" all the way through and including pages #10 & #11 "Making The Cut". Your two side pieces should resemble shown below in **Fig. 42**.



## Set-up For The Front & The Back of Box

Now that the sides of our box are complete we need to cut the front and back. Follow the instructions outlined on page #11 starting with "Set-up For The Front and Back Of The Box" all the way through to and including "Making The Cut" on page #12. Your two front and back pieces should resemble the photograph shown in **Fig. 43**.



## End To End Joints

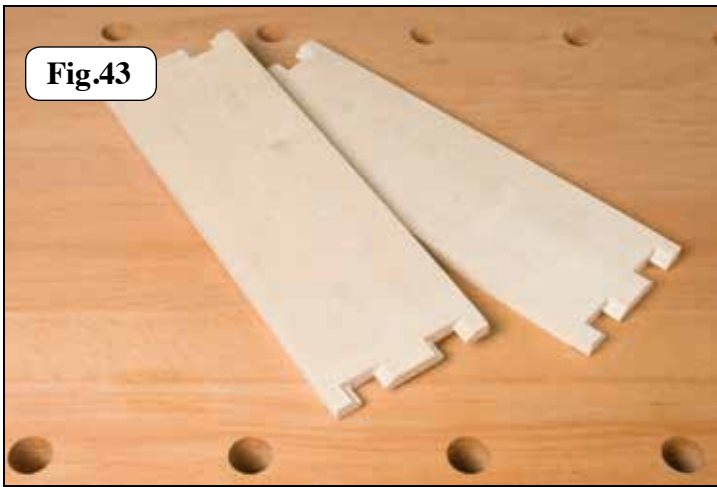

Fig.43

### Shop Notes:

*When making a three dimensional cut, the router will cut into a portion of your MDF sub-plate of the right angle fence. The MDF sub-plate is a sacrificial component and can be replaced as needed.*

### Assemble the box:

Assemble all four sides of the box. Your completed box should resemble the photograph shown below in **Fig. 44**. The joints should have a snug - sliding fit. If you have to force the joint together with a mallet, it may result in splitting your stock, as well as forcing the glue out of the joint. To loose of a fit may produce wobbling and a weak joint. If satisfied with the fit of your joints, glue, clamp and finish your project. If your joint needs adjusting see page #32 "Fast-Joint Tips".



Fig.44

Follow these same basic instructions for cutting the Hearts template, Key template, Heart Wave template, Large Key template, Lock template, Wave template, Lolli-pop template, Arrowhead template and Teddy bear template.

End to end style joints are generally used as a decorative type of joint. Most woodworkers will use two different species of wood when making this kind of joint. This style of joint we will be making is exactly the same process as the four sided box we just made with a couple of exceptions. The first exception is, both sides of the joint are made from the same thickness stock. The second exception is, the female side of the joint is cut laying flat on the jig. We will be using the Heart templates in this example, both the left and the right side of this joint will be made from 3/8" stock.

### Set-up For The Male Side of The Joint:

Follow the instructions outlined on page #9 starting with "Set Up Router Bit Height" all the way through and including pages #10 & #11 "Making The Cut". The male side of your stock should resemble the photo shown below in **Fig. 45**.

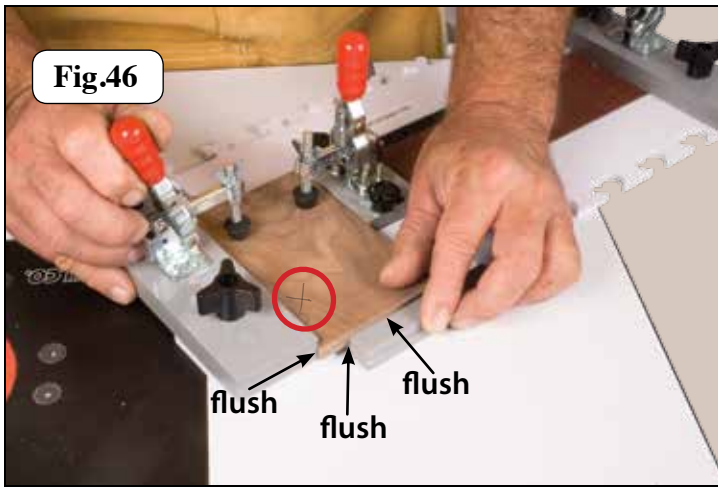

Fig.45

### Set-up For The Female Side of The Joint:

Now that the male side of our joint is complete we need to cut the female side of the joint. The height of the router bit does not change for this cut. For this cut you can place the stock flat on either the left side or the right side of your jig. Place a reference mark (X) on side edge of the stock. This edge must always be placed up against the template alignment block for the joint to align properly. Adjust the rubber feet on the toggles for the thickness stock your are cutting. Your toggle clamp should produce a slight snap when engaged. If the toggle is to tight it may cause the jig to flex. If you are cutting smaller stock, add the third toggle to the jig and adjust the third toggle for the thickness and width of stock if needed. With your stock on the jig and your reference mark facing the template alignment block, place your gray set-up block with the wide side facing down on your router table. Slide the

block up against the edge of the female Heart template. While holding the set-up block against the edge of the Heart template, slide your stock up against your template alignment block. Next, slide your stock forward until it contacts the set-up block and secure in place with toggle clamp (See Fig. 46).



Follow all of the instructions outlined on pages #10 & #11 "Making The Cut". The the female side of your stock should resemble shown below in Fig. 47.



### Assemble The Joint:

Assemble your joint. Your completed end to end joint should resemble the photograph in Fig. 48. The joints should have a snug - sliding fit. If you have to force the joint together with a mallet, it may result in splitting your stock, as well as forcing the glue out of the joint. To loose of a fit may produce wobbling and a weak joint. If satisfied with the fit of your joints, glue, clamp and finish your project. If your joint needs adjusting see page #32 "Fast-Joint Tips".



Fig.48

## Decorative Dental Moulding

The Fast-joint™ is capable of producing all types of decorative types of molding. You can use either the male template or the female template for this type of molding. To make this type of cut, the stock is always placed flat on to the platform of the jig, regardless of which template you are using. Use the same instructions on page #10 "Set-up For The Sides Of The Box". Once completed, simply cut-off the end of your stock with a miter saw or table saw to the width of molding you desire (See Fig. 49).

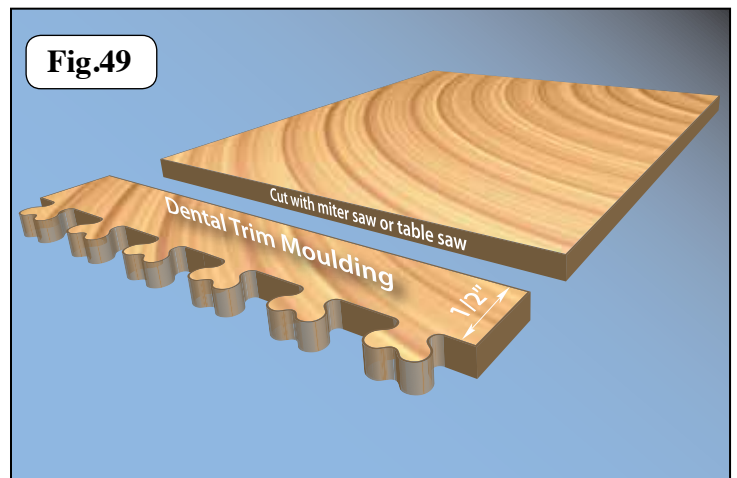

Fig.49

## Half Blind Dovetail

Cutting dovetails with the Fast-joint™ system couldn't be easier. A half blind dovetail joint is only visible from one side and are commonly used for building drawers. We will be building a 10" x 10" drawer box with the front and back being made out of 3/4" stock and the sides being made from 1/2" stock. Install the half blind dovetail / pin and tail templates on to your jig and secure in place. You will be using the half blind dovetail / pins template to make the sides of your drawer. The half blind dovetail / tails template will be used to make the front and back of your drawer. Start by installing the 7/16" bushing on to your router plate, and secure in place with locking nut and washer. Next, install the 1/2" - 14° dovetail router bit into your router and secure the router collet. Place the 3/8" brass bar on top of your jig, adjust the router bit height to the top of the brass bar and lock in place (See Fig. 50). Once you have set-up your bit height, you should not have to adjust for the matching cuts.



Fig.50

### Shop Notes:

An easy rule for adjusting the fit of a dovetail joint is; heighten the bit to tighten the joint, lower the bit to loosen the joint (highly - tightly, lower - loosey).

## Cutting The Pins: (sides of drawer)

We will be making the cuts on the sides of our drawer first using the half blind dovetail / pins template on the jig with the right angle fence. Place the right angle fence on to the jig between the template alignment blocks, with the non-slip abrasive strip facing the pin side of the jig. Adjust the rubber feet on the toggles for the thickness of the MDF sub-plate. Your toggle clamp should produce a slight snap when engaged. If the toggle is too tight it may cause the jig to flex. Place a reference mark on the side edge of the stock (X). This edge must always be placed up against the template alignment block for the joint to align properly. Place the side of your drawer box vertically, on the jig, in front of the right angle fence, with the reference side against the template alignment block. With your stock on the jig and your reference mark facing the template alignment block, place your gray set-up block with the wide side facing down on your router table. Slide the block up against the edge of the half blind dovetail / pins template. While holding the set-up block against the edge of the Pins template, slide the right angle fence and stock up against your set-up block until flush. Secure the MDF sub-plate with toggle clamps (See Fig. 51).

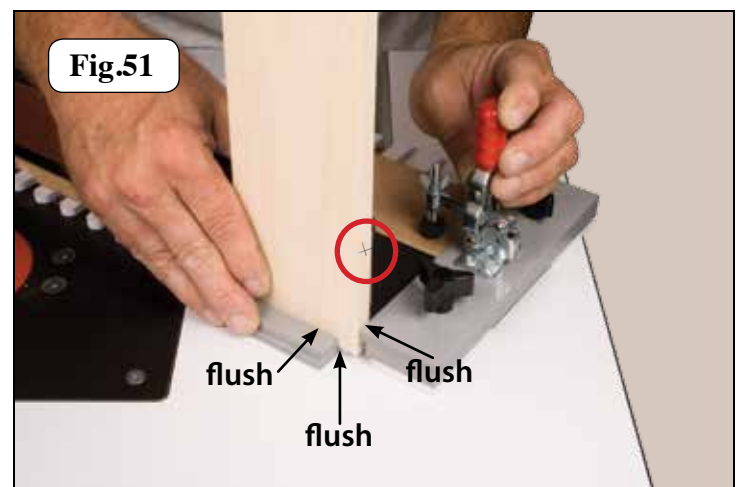
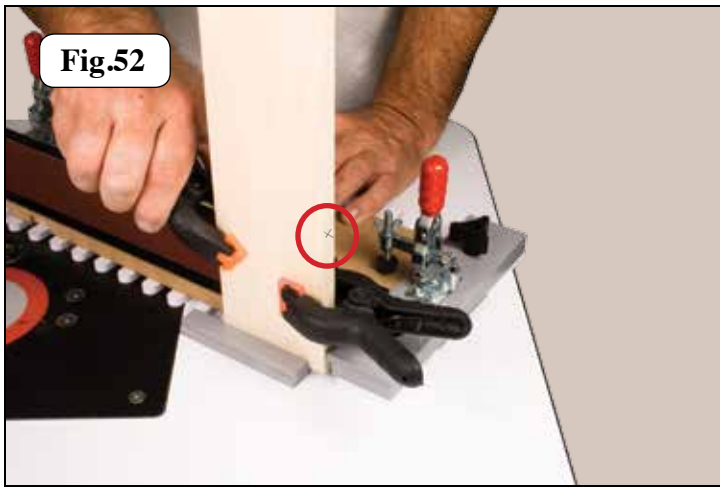

Fig.51

Now that the right angle fence is secure, slide the reference side of the stock against the template alignment block. Clamp the stock to the right angle fence using the two spring clamps that came with the Fast-joint system (See Fig. 52).

### Shop Notes:

If you are cutting long stock, it is recommended to clamp your stock to the right angle fence using C-clamps or F-clamps.



**Fig.52**

**Caution**

*When the first cut is made into the plastic template alignment blocks, the router bit may have a tendency to grab the jig and cut excessively.*

Once contact is made, slowly guide the profile of the template against the bushing and router bit so that your material is cut in the shape of the template, working from the outer edge of the jig to the inside edge of your stock. (See Fig. 54)

**Caution**

*When clamping your stock to the right angle fence, always make sure that the clamps do not interfere with the cutters. Doing so may result in damaging your cutters or even injury.*

**Making The Cut:**

The first time you use each style of template, it is perfectly normal to cut into the template alignment blocks. The template alignment blocks are made from a durable polyethylene plastic, and should last for many projects. At the point that they no longer provide support, you can reverse them and use the outer edges or replace them with new ones. We start our cut approximately 1/4" in from the inside edge of the template alignment block. Make sure the router bit is not contacting the surface of the stock or any part of the Fast-joint jig before turning on your router. Turn the router on. Firmly grasp the jig at both ends and slide the jig forward until the template contacts the bushing (See Fig. 53).



**Fig.54**

After the first cut is made, you should make multiple passes to make sure all the material has been removed, working from the outer edge of the jig to the inside edge of your stock. Your cut should resemble the photograph in Fig. 55.



**Fig.53**

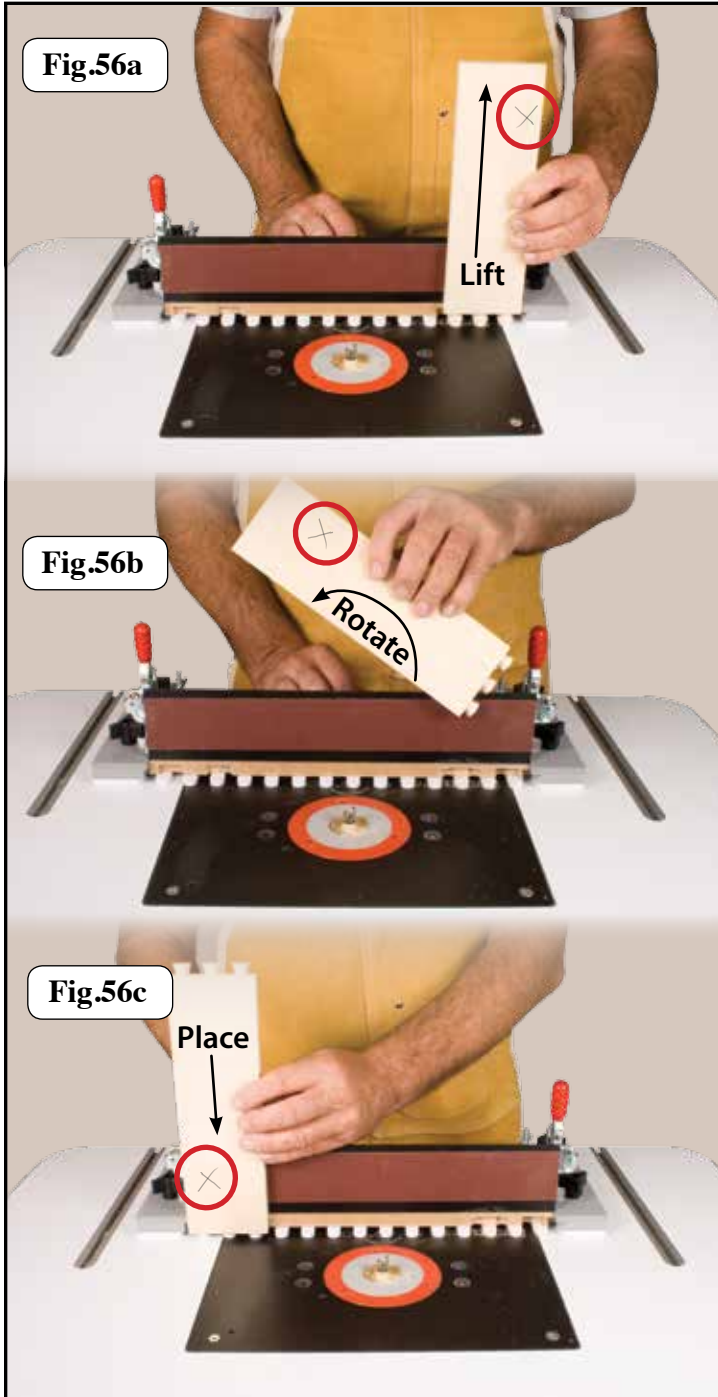

**Fig.55**

*Shop Notes:*

*Always make sure that no chips or saw dust are caught between the template and the bushing. If there is any debris, it may result in poorly fitting joints.*

Now that one end of the drawer is cut, you will now cut the opposite end of the stock using the same reference mark. In order to do this, you will place the opposite end of the stock vertically on the other side of the jig, in front of the right angle fence, with the reference side against the opposite template alignment block (See **Fig. 56a**, **56b**, and **56c**). The reason why we move to the other side of the jig, is to have the same entry point on the opposite side of the stock we are cutting, so that all four sides of the drawer box will fit together properly.



*Shop Notes:*

*Always remember to keep the reference mark you made against the same template alignment block you started with. Failing to do so may result in un-even joints.*

Once in place following the same instructions outlined in "Cutting The Pins" on page #19 for set-up. Once the stock is properly set-up and secure in the jig, make the cut (See **Fig. 57**). After making this cut, repeat this entire process on the other side of your drawer box.

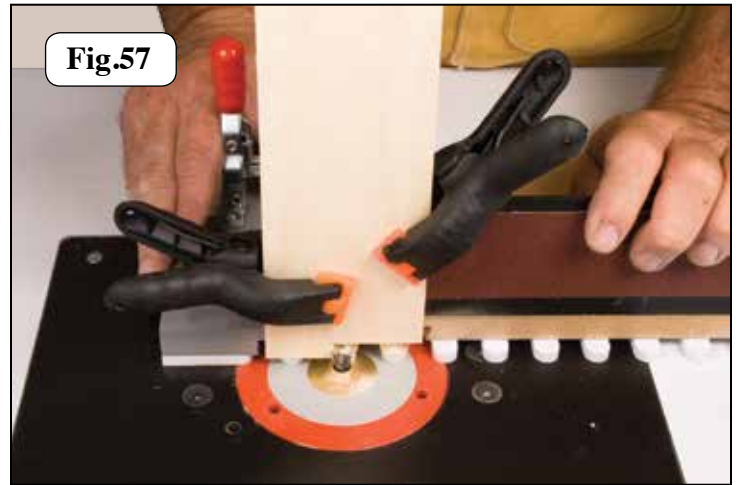

Your completed side pieces should resemble the photograph shown below in **fig. 58**.

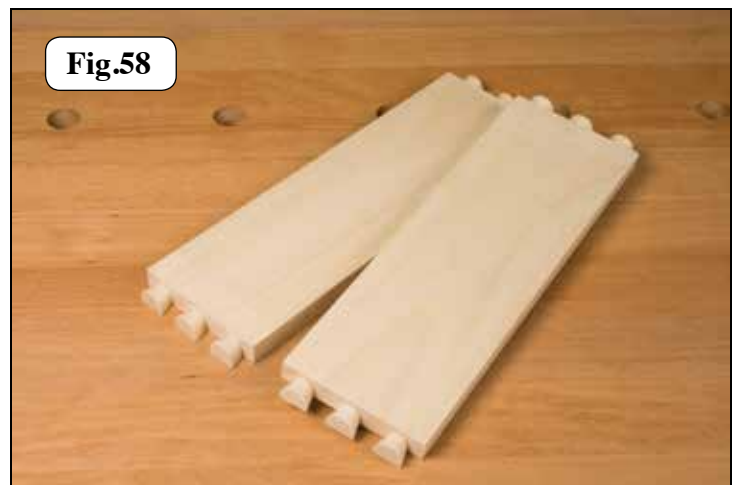

## Cutting The Tails: (Front & Back of drawer)

We will be making the cuts on the front and back of our drawer first using the half blind dovetail / tail template on the jig. Before we get started we must make a reference line on our template to achieve the correct depth of cut for the tails. This line is achieved by using our pin stock as a gauge. Place the pin stock vertically on the half blind dovetail / tails template. Align the pin stock with the inside edge of the tails template. Use masking tape or a fine tipped pencil, place a line on the template along the outside edge of the pin stock (See Fig. 59).

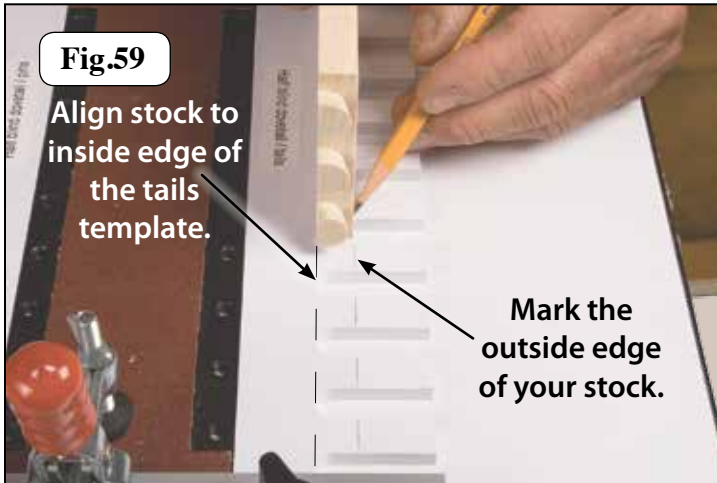

Place a reference mark on side edge of the stock (X) of your drawer. This edge must always be placed up against the template alignment block for the joint to align properly. With your template marked for the depth of cut place the stock flat on the jig. Adjust the rubber feet on the toggles for the thickness stock your are cutting. Your toggle clamp should produce a slight snap when engaged. If the toggle is to tight it may cause the jig to flex. If you are cutting smaller stock, add the third toggle to the jig and adjust the third toggle for the thickness and width of stock if needed. With your stock on the jig and your reference mark facing the template alignment block, slide your tail stock to the pencil line on your template. Next, with your tail stock up against the template alignment block and flush with the pencil line secure in place with toggle clamps (See Fig. 60).

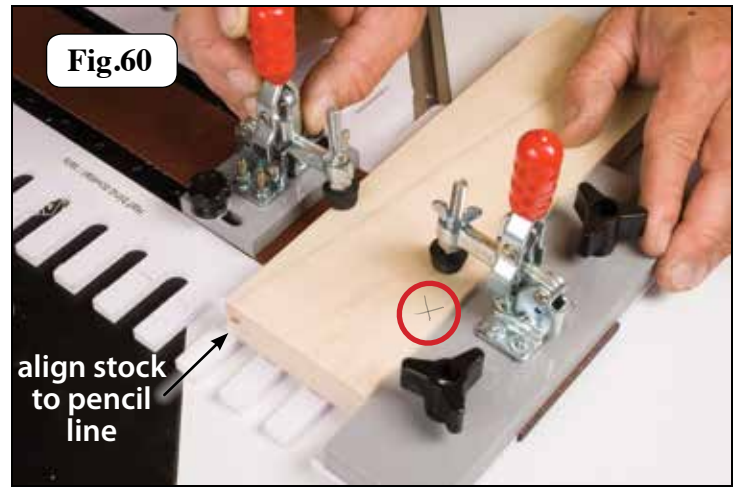

## Making The Cut:

The first time you use each style of template, it is perfectly normal to cut into the template alignment blocks. The template alignment blocks are made from a durable polyethylene plastic, and should last for many projects. At the point that they no longer provide support, you can reverse them and use the outer edges or replace them with new ones. We start our cut approximately 1/4" in from the inside edge of the template alignment block. Make sure the router bit is not contacting the surface of the stock or any part of the Fast-joint jig before turning on your router. Turn the router on. Firmly grasp the jig at both ends and slide the jig forward until the template contacts the bushing (See Fig. 61).



## Caution

*When the first cut is made into the plastic template alignment blocks, the router bit may have a tendency to grab the jig and cut excessively.*

Once contact is made, slowly guide the profile of the template against the bushing and router bit so that your material is cut in the shape of the template, working from the outer edge of the jig to the inside edge of your stock. (See **Fig. 62**)

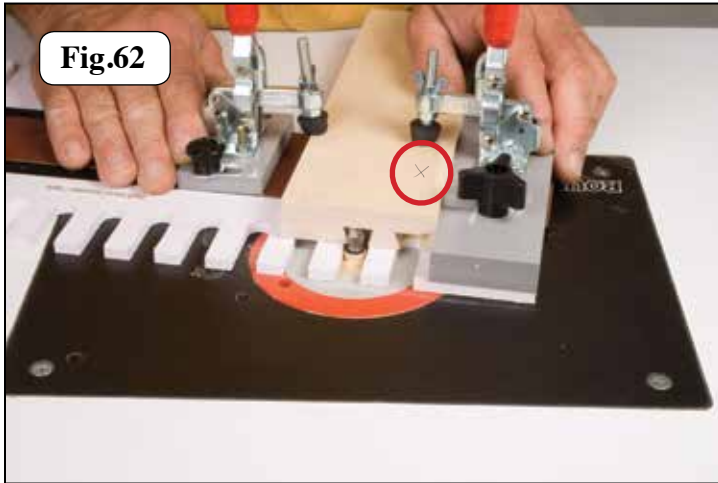

After the first cut is made, you should make multiple passes to make sure all the material has been removed, working from the outer edge of the jig to the inside edge of your stock. Now that one end of the drawer box is cut, you will now rotate the stock to the other side of the jig, keeping your reference mark against the template alignment block, and following the same instructions outlined in "Cutting the tails" on page #22 for set-up. Once the stock is properly set-up and secure in the jig, make the cut (See **Fig. 63**). After making this cut, repeat this entire process on the back side of your drawer box.

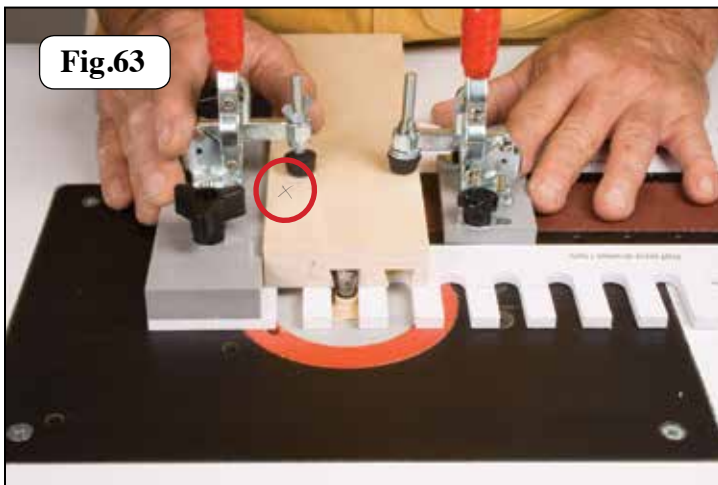

Your completed front and back pieces should resemble the photograph shown in **fig. 64**.

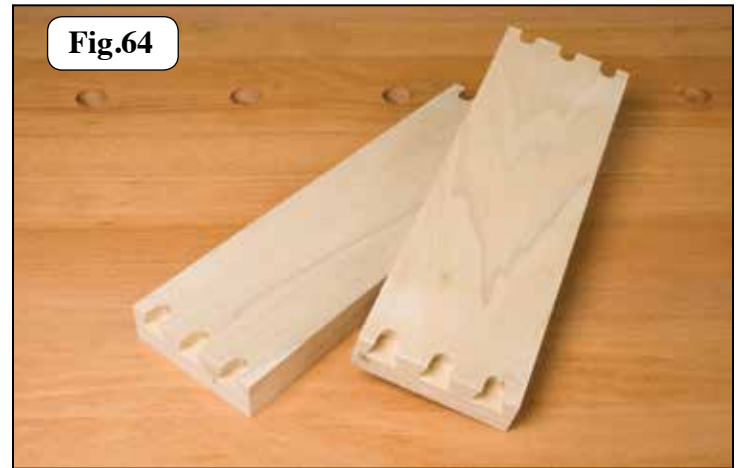

### Assemble the Drawer box:

Assemble all four sides of the drawer box. Your drawer completed box should resemble the photograph shown below in **Fig. 65**. The joints should have a snug - sliding fit. If you have to force the joint together with a mallet, it may result in splitting your stock, as well as forcing the glue out of the joint. To loose of a fit may produce wobbling and a weak joint. If satisfied with the fit of your joints, glue, clamp and finish your project. If your joint needs adjusting see page #32 "Fast-Joint Tips".



### Shop Notes:

*Always make sure that no chips or saw dust are caught between the template and the bushing. If there is any debris, it may result in poorly fitting joints.*

## Through Dovetails

A through dovetail joint is visible from all four sides. This joint can be used for all types of projects. When cutting through dovetails you are limited to 1/4" to 3/8" maximum thickness stock on all four sides. We will be building a 10" x 10" drawer box with all four sides being made from 3/8" stock. Install the half blind dovetail / tail template on one side of the jig and the through dovetail / tail template on the other side of your jig, secure in place. Start by installing the 7/16" bushing on to your router plate, and secure in place with locking nut and washer. Next, install the 1/2" - 14° dovetail router bit into your router and secure the router collet. Place the 3/8" brass bar on top of your jig, adjust the router bit height to the top of the brass bar and lock in place (See Fig. 66).



Fig.66

### Set-up For The Pin Cut:

We will be making the cuts on the front and back of our box using the half blind dovetail / tails template and the right angle fence. Place the right angle fence on to the jig between the template alignment blocks, with the non-slip abrasive strip facing the half blind dovetail / tails template side of the jig. Adjust the rubber feet on the toggles for the thickness of the MDF sub-plate. Your toggle clamp should produce a slight snap when engaged. If the toggle is too tight it may cause the jig to flex. Place a reference mark on the side edge of the stock (X). This edge must always be placed up against the template alignment block for the joint to align properly. Place the front of your box vertically, on the jig, in front of the right angle fence, with the reference side against the template alignment block. With your stock on the jig and your refer-

ence mark facing the template alignment block, place your gray set-up block with the narrow side facing down on your router table. Slide the block up against the edge of the half blind dovetail / tails template. While holding the set-up block against the edge of the half blind dovetail / tails template, slide the right angle fence and stock up against your set-up block until flush. Secure the MDF sub-plate with toggle clamps (See Fig. 67).

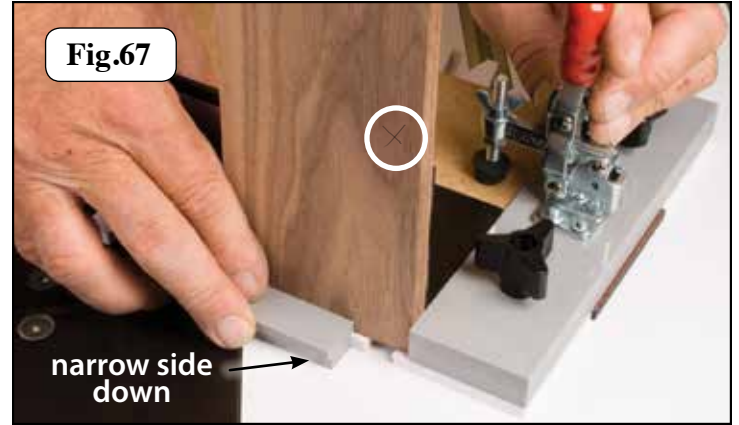

Fig.67

Now that the right angle fence is secure, slide the reference side of the stock against the template alignment block. Clamp the stock to the right angle fence using the two spring clamps that came with the Fast-joint™ system (See Fig. 68).

### Shop Notes:

*We are using the half blind dovetail / tail template to cut the Pin of this joint, because the edge of the template is square to allow for maximum capacity.*



Fig.68

### Caution

*When clamping your stock to the right angle fence, always make sure that the clamps do not interfere with the cutters. Doing so may result in damaging your cutters or even injury.*



## Making The Cut:

The first time you use each style of template, it is perfectly normal to cut into the template alignment blocks. The template alignment blocks are made from a durable polyethylene plastic, and should last for many projects. At the point that they no longer provide support, you can reverse them and use the outer edges or replace them with new ones. We start our cut approximately 1/4" in from the inside edge of the template alignment block. Make sure the router bit is not contacting the surface of the stock or any part of the Fast-joint jig before turning on your router. Turn the router on. Firmly grasp the jig at both ends and slide the jig forward until the template contacts the bushing (See Fig. 69).



### Caution

*When the first cut is made into the plastic template alignment blocks, the router bit may have a tendency to grab the jig and cut excessively.*

Once contact is made, slowly guide the profile of the template against the bushing and router bit so that your material is cut in the shape of the template, working from the outer edge of the jig to the inside edge of your stock. (See Fig. 70)

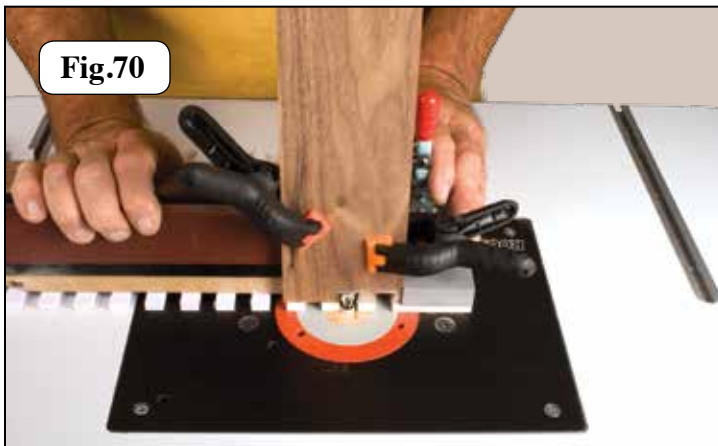

Now that one end of the drawer is cut, you will now cut the opposite end of the stock using the same reference mark. In order to do this, you will place the opposite end of the stock vertically on the other side of the jig, in front of the right angle fence, with the reference side against the opposite template alignment block (See Fig. 71a, 71b, and 71c). The reason why we move to the other side of the jig, is to have the same entry point on the opposite side of the stock we are cutting, so that all four sides of the box will fit together properly.

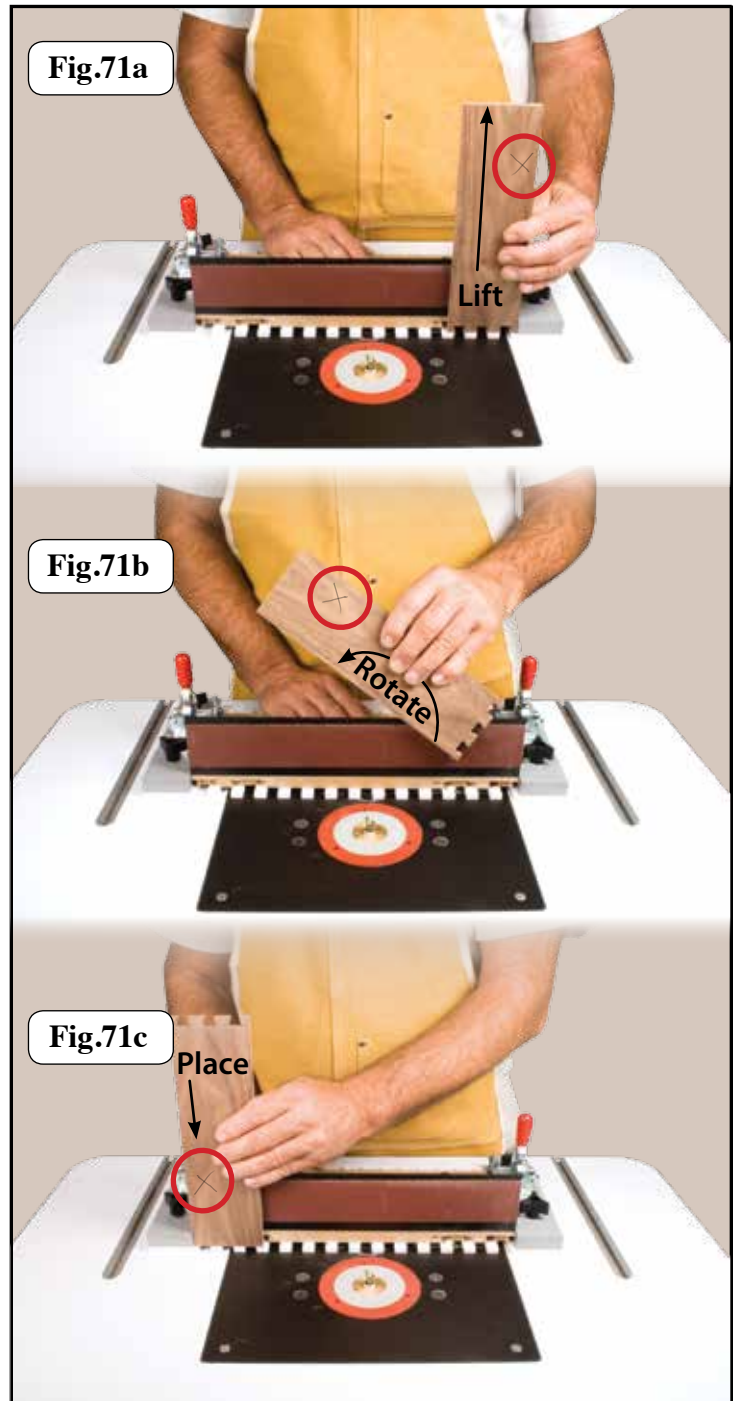

Once in place, follow the same instructions outlined in "Set-up for Pin Cut" on page #24 for set-up. Once the stock is properly set-up and secure in the jig, make the cut (See **Fig. 72**). After making this cut, repeat this entire process on the back side of your box.

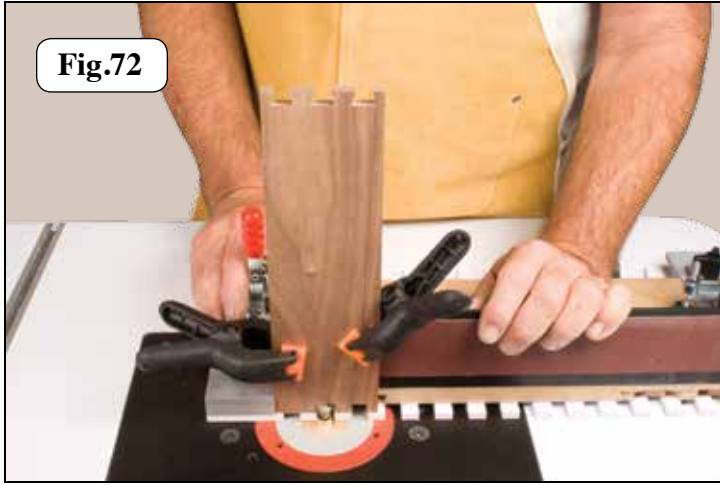

**Fig.72**

Your completed front and back pieces should resemble the photograph shown below in **fig. 73**.

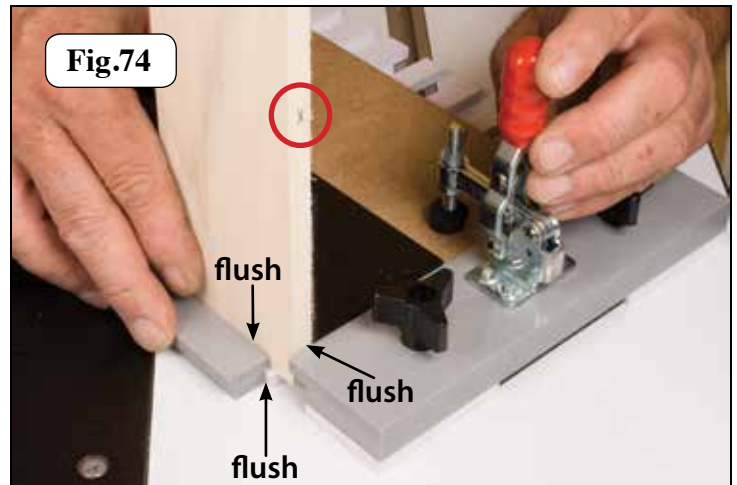

**Fig.73**

### Set-up For The Tail Cut:

Now that the front and back of our box are complete we need to cut the sides. Start by removing the dovetail bit and the 7/16" guide bushing. Place the standard bushing into your router plate and secure in place with locking nut and washer. Install the 3/16" up-cut spiral router bit into the router and secure collet. Set the router bit height to 3/8" above the face of the template, using the brass bar as shown on page 24, **Fig. 66**. The height of the router bit must be the same height that we set the dovetail bit at for this cut. We will be making the cuts on the sides of our box using through dovetail / tail template on the jig with the right angle fence. If you we're using the third toggle,

you will now remove it from the jig. Place the right angle fence on to the jig between the template alignment blocks, with the non-slip abrasive strip facing the through dovetail / tail side of the jig. Adjust the rubber feet on the toggles for the thickness of the MDF sub-plate. Your toggle clamp should produce a slight snap when engaged. If the toggle is too tight it may cause the jig to flex. Place a reference mark on the side edge of the stock (X). This edge must always be placed up against the template alignment block for the joint to align properly. Place the side piece of your box vertically, on the jig, in front of the right angle fence, with the reference side against the template alignment block. With your stock on the jig and your reference mark facing the template alignment block, place your gray set-up block with the narrow side facing down on your router table. Slide the block up against the edge of the through dovetail / tails template. While holding the set-up block against the edge of the through dovetail / tail template, slide the right angle fence and stock up against your set-up block until flush. Secure the MDF sub-plate with toggle clamps (See **Fig. 74**).

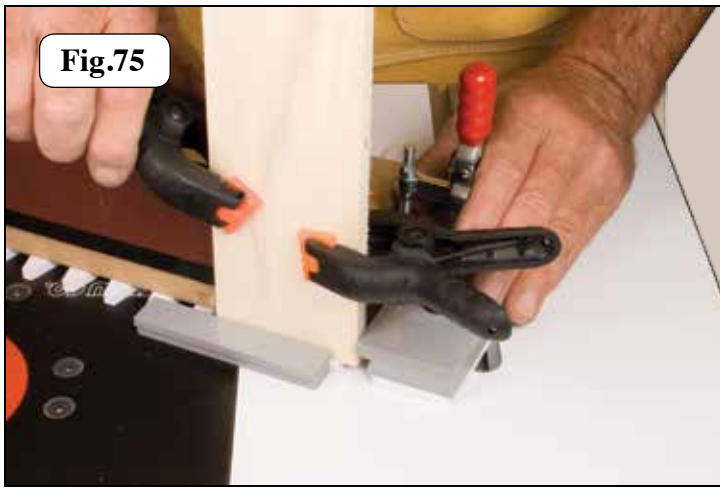

**Fig.74**

Now that the right angle fence is secure, slide the reference side of the stock against the template alignment block. Clamp the stock to the right angle fence using the two spring clamps that came with the Fast-joint system (See **Fig. 75**).

### Shop Notes:

*If you are cutting long stock, it is recommended to clamp your stock to the right angle fence using C-clamps or F-clamps.*

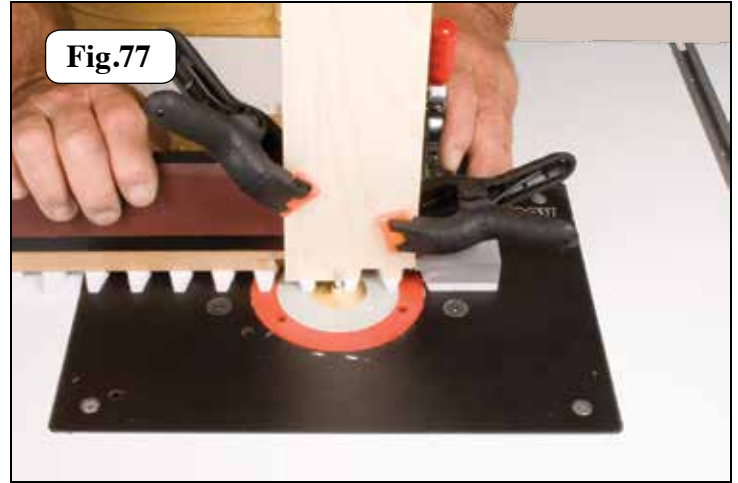

**Fig.75**

**Making The Cut:**

The first time you use each style of template, it is perfectly normal to cut into the template alignment blocks. The template alignment blocks are made from a durable polyethylene plastic, and should last for many projects. At the point that they no longer provide support, you can reverse them and use the outer edges or replace them with new ones. We start our cut approximately 1/4" in from the inside edge of the template alignment block. Make sure the router bit is not contacting the surface of the stock or any part of the Fast-joint jig before turning on your router. Turn the router on. Firmly grasp the jig at both ends and slide the jig forward until the template contacts the bushing (See **Fig. 76**).

Once contact is made, slowly guide the profile of the template against the bushing and router bit so that your material is cut in the shape of the template, working from the outer edge of the jig to the inside edge of your stock. (See **Fig. 77**)



**Fig.77**

Your completed tail cut should resemble the photograph shown below in **fig. 78**.

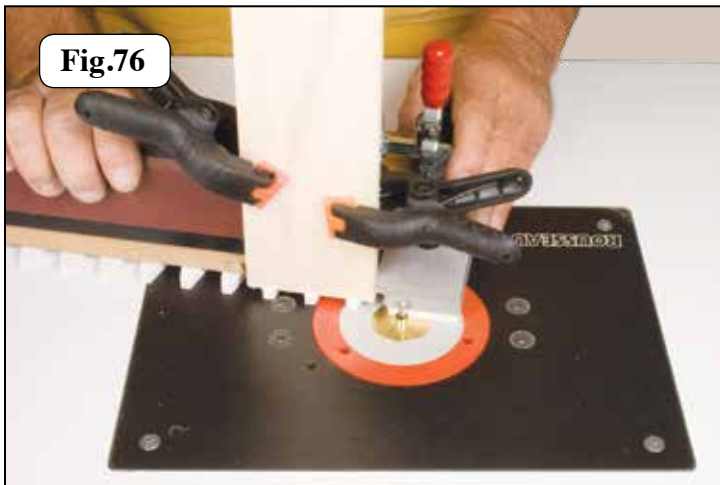

**Fig.76**

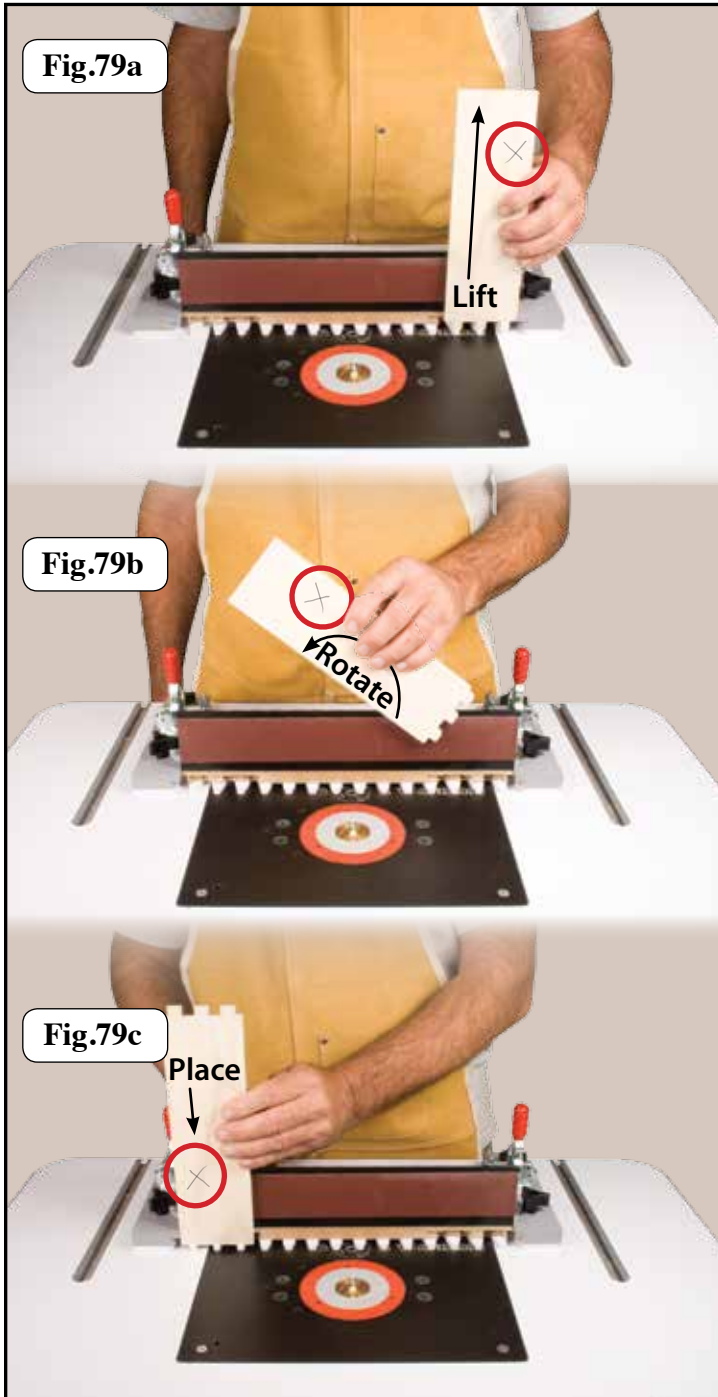

**Fig.78**

**Caution**

*When the first cut is made into the plastic template alignment blocks, the router bit may have a tendency to grab the jig and cut excessively.*

Now that one end of the drawer is cut, you will now cut the opposite end of the stock using the same reference mark. In order to do this, you will place the opposite end of the stock vertically on the other side of the jig, in front of the right angle fence, with the reference side against the opposite template alignment block (See **Fig. 79a**, **79b**, and **79c**). The reason why we move to the other side of the jig, is to have the same entry point on the opposite side of the stock we are cutting, so that all four sides of the box will fit together properly.



Once in place following the same instructions outlined in "Set-up For Tail Cut" on page #26 for set-up. Once the stock is properly set-up and secure in the jig, make the cut (See **Fig. 80**). After making this cut, repeat this entire process on the back side of your box.

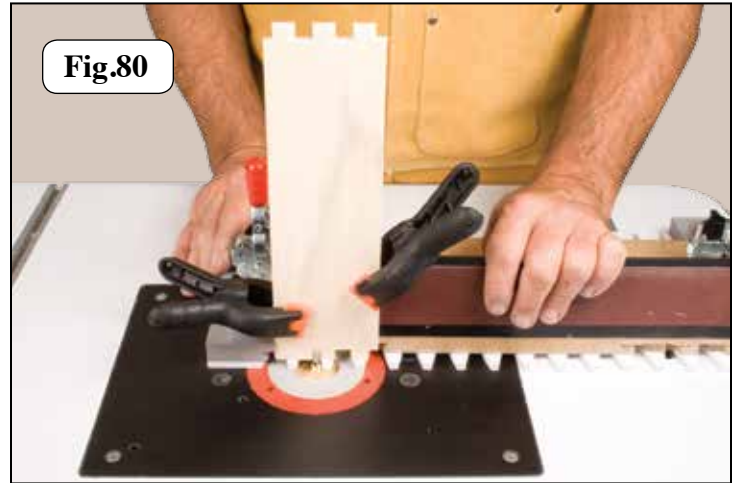

Your completed front and back pieces should resemble the photograph shown below in **Fig. 81**.



### Assemble the box:

Assemble all four sides of the box. Your completed box should resemble the photograph shown below in **Fig. 82**. The joints should have a snug - sliding fit. If you have to force the joint together with a mallet, it may result in splitting your stock, as well as forcing the glue out of the joint. To loose of a fit may produce wobbling and a weak joint. If satisfied with the fit of your joints, glue, clamp and finish your project. If your joint needs adjusting see page #32 "Fast-Joint Tips".

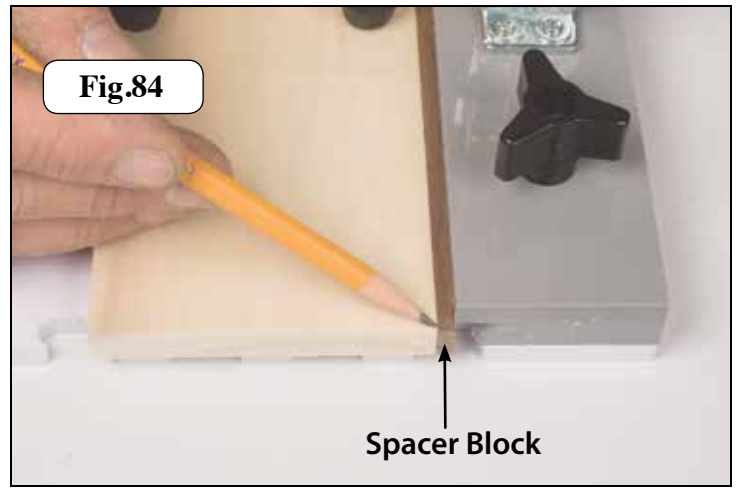

## Centering Your Material

Creating a centered joint with the Fast-joint™ system is a simple process. We will be using the Key template in this example. If your stock does not perfectly center (See Fig. 83) follow instructions below.

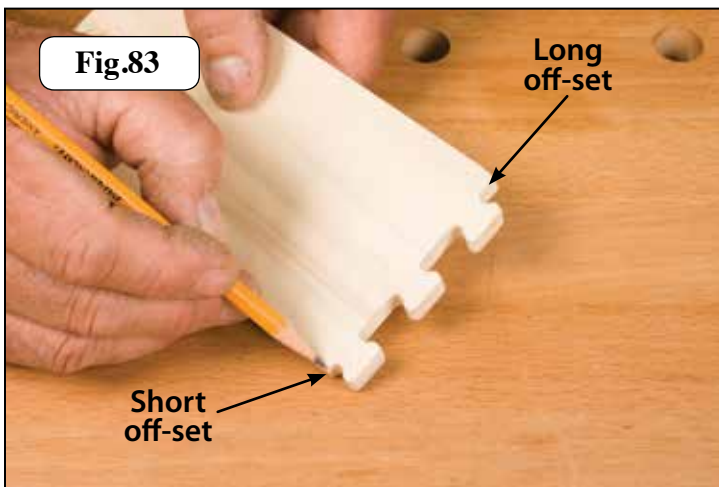

Your completed centered piece should resemble the photograph shown below in fig. 85.

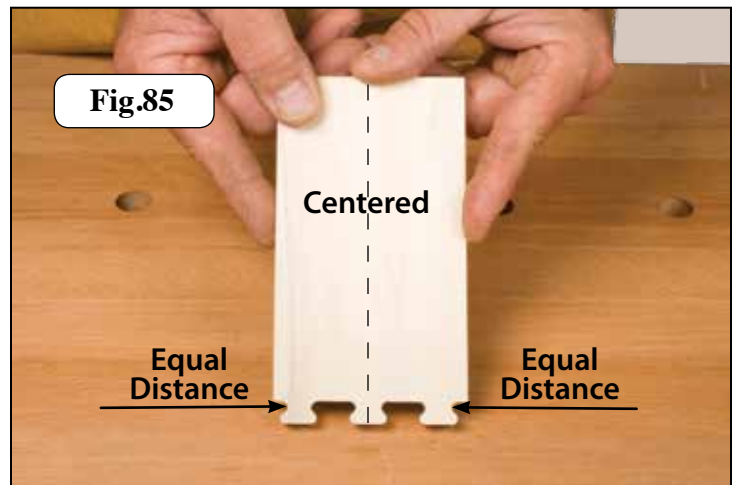

Place your stock to be cut flat on the Fast-joint™ jig up against a template alignment block. Slide your stock away from the template alignment block until the Keys are centered underneath your stock and clamp the stock in place with toggle(s). Next, we will make a "spacer block". With stock secured, measure the distance from the template alignment block to the edge of your stock. Once distance is measured, rip a piece of stock to the width you just measured and at least as long as the your stock piece. This will be our "spacer block". Place the "spacer block" between the template alignment block and the your stock piece as shown in fig. 84 with the stock piece now centered to the template. Make the cut.

### *Shop Notes:*

*If you're using a spacer block for alignment, you must use on both the male and female cuts in order for the stock to align properly.*





## Fast-Joint™ Joining System

The Fast-Joint™ Precision Joinery System is one of the most versatile jigs available. In this manual we have outlined several different types of joints as well as thickness stock that can be made. The possibilities that can be applied are virtually endless. Thank you for your purchase and we hope you enjoy your brand new Fast-Joint™ Precision Joinery System!



## *Fast-Joint tips:*

### **Sloppy Joints:**

After making our cuts we sometimes notice that the joint does not fit quite as snug as we would like. One thing you will want to make sure of is, the router bit must be centered to the guide bushing. If after making sure the router bit is centered and the joint is still not properly fitting, install the tight bushing into the router plate.

### **Joint To Tight:**

This is usually caused by dull cutters on your router bit. Make sure you are using a sharp cutter when cutting your joints. Another reason for tight joints is, the material was not fully removed during the cut, in other words, you may have not made enough passes. Make a couple more passes to clean up the joint. Tight joints can also be caused by build up of debris between the template and the bushing. Make sure the area between the template and bushing are as clean as possible during your cutting process.

### **Edges Not Aligning Properly:**

Generally, this occurs when your Fast-joint™ system is not square. Make sure that your jig is set up properly, to do this refer to the instructions in this manual on page numbers 5 and 6. Another cause of mis-aligned edges is your wood may not have been firmly placed against the template alignment blocks during the cutting process. Make sure before cutting that your stock is firmly in place and secure before cutting.

### **Stock Movement During Cut:**

This is usually caused by the sandpaper strip losing it's grip from either wear and tear or improper installation. Make sure the sandpaper is properly installed as described on page #4. If the sandpaper strip is worn, remove it and replace it with a new one. TIP: One way to prolong the life of you sandpaper is to keep free of build-up. A simple way to do this is to use a belt cleaning stick and clean the strip between every use.

### **Jig Bows During Use:**

If the Fast-joint™ system bows at anytime during use, this means your toggle clamps are securing the stock to tightly. To fix this, loosen the rubber feet on the toggle clamps just enough to produce a light snap when engaged on to your stock. The Fast-joint™ platform should sit flat on your table top surface at all times.

# *Fast-Joint*

Manufactured by Fulton Woodworking  
Tools & Accessories

For technical issues or questions please call toll free at:  
1-888-512-9069